



DOUBLE FERRULE FITTINGS



INTRODUCTION

Fluid Controls® Double Ferrule Compression Tube Fittings provide leak proof torque free seals at all tubing connections. They eliminate hazardous leaks in instrumentation, process, pneumatic, hydraulic, gas and other applicable tubing systems which could otherwise turn out to be costly to the installation.

- The basic Fluid Controls® Double Ferrule Tube Fitting is a four piece Fitting consisting of the Nut, the Back Ferrule, the Front Ferrule and the Body. When installed, it becomes a five piece connection with the addition of the tubing and provides a solid leak-free joint.
- The two ferrules grasp tightly around the tube with no damage to the tube wall. Exhaustive tests have proven that the tubing will yield before a Fluid Control Double Ferrule joint starts leaking.
- The secret behind the success of the Fluid Controls® Double Ferrule Fitting lies in the two ferrule design which is a combination of geometry and metallurgy. All the action in the fitting is by an axial movement along the tube (instead of a rotary motion) to create the joint. This axial movement prevents any torque transmittal from the fitting to the tubing. Since there is no initial strain on the tubing, the making of the joint does not weaken the tubing.
- Another advantage of the Fluid Controls® Double Ferrule Fitting is that the sequential action of the twin ferrules overcomes variations in the wall thickness, hardness and dimensional tolerance of the tubes. In this way, proper ferrule interaction compensates for most of the variables which lead to failure in other fittings.
- Fluid Controls® Double Ferrule Fittings are easy to install and require no special tools in the process. They are reusable several times and can withstand heavy impulse and vibration both in vacuum and pressure systems. Absence of damage to the tube surface prevents fatigue failure.

Fluid Controls® Double Ferrule Compression Tube Fittings have the following features and advantages:

DESIGN

- Self-aligning
- Works on thick and thin wall tubing
- Resists vibration
- Works on a variety of tube materials
- As all components are made of the same material, the fittings possess thermal compatibility and corrosion resistance
- Demonstrates resistance to temperature cycling
- Compensates for the variables encountered in tube materials
- Does not significantly reduce flow area

PERFORMANCE

- Works on vacuum as well as low and high pressures
- Seals at low cryogenic temperatures as well as elevated temperatures rated for the tube
- Seals consistently over a wide range of temperature cycling
- Seals repeatedly under make and break conditions
- Resistant to pressure up to the burst point with the tubing without leakage

ASSEMBLY

- Uses geometry rather than torque for uniformity of make-up. It requires only one-and-a-quarter turns after snug tight to complete the joint
- Does not require dis-assembly and inspection of ferrule swaging at every make-up
- Does not require any special tools for assembly

SERVICE

Fluid Controls® Double Ferrule Tube Fittings are available in a wide range of materials, sizes, connections and configurations from our local distributors with substantial back up stocks to support our dealers' inventories.

PRODUCT LOCATOR



Front & Back Ferrule
Fractional & Metric Tube
page- 10



Coupling Cap
Fractional & Metric Tube
page- 10



Tube End Closure
Fractional & Metric Tube
page- 11



Fitting End Closure
Fractional & Metric Tube
page- 11



Union
Fractional & Metric Tube
page- 12

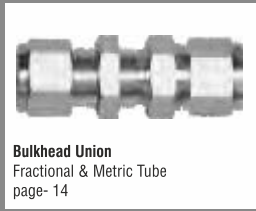

Bulkhead Union
Fractional & Metric Tube
page- 14

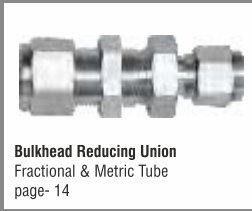

Bulkhead Reducing Union
Fractional & Metric Tube
page- 14



Union Elbow
Fractional & Metric Tube
page- 15



Bulkhead Elbow
Fractional & Metric Tube
page- 15



Union Tee
Fractional & Metric Tube
page- 16

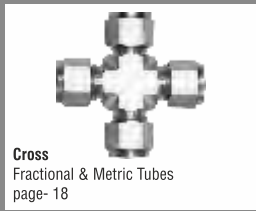

Cross
Fractional & Metric Tubes
page- 18



Male Connector
Fractional & Metric Tube to
NPT thread & ISO tapered pipe thread
page- 19, 20 & 21



Male Connector
Fractional & Metric Tube to
ISO parallel thread - Rp
page- 22



Male Connector
Fractional & Metric Tube to
ISO parallel thread - Rs
page- 23

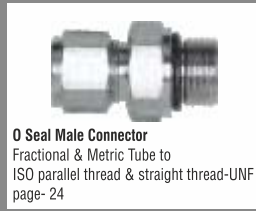

O Seal Male Connector
Fractional & Metric Tube to
ISO parallel thread & straight thread-UNF
page- 24



Male Elbow
Fractional & Metric Tube to
NPT thread & ISO tapered pipe thread
page- 26 & 27



45 Degree Male Elbow
Fractional & Metric Tube to
NPT parallel thread
page- 28



45 Deg. Positionable Male Elbow
Fractional & Metric Tube to
NPT parallel thread
page- 28



Positionable Male Elbow
Fractional & Metric Tube to
ISO parallel thread
SAE / MS straight thread
page- 29



Male Run Tee
Fractional & Metric Tube to NPT thread
page- 30



Positionable Male Run Tee
Fractional & Metric Tube to ISO
parallel thread SAE / MS straight thread
page- 32 & 33



Positionable Male Branch Tee
Fractional & Metric Tube to ISO
parallel thread SAE /MS straight thread
page-32 & 33



Female Connector
Fractional & Metric Tube to
NPT thread & ISO tapered pipe thread
page- 34 & 35



Female Manometer Connector
Fractional & Metric Tube to
ISO parallel thread (gauge)
page- 36



Bulkhead Female Connector
Fractional & Metric Tube to NPT thread
page- 37



Female Run Tee
Fractional & Metric Tube to NPT thread
page- 40



Female Branch Tee
Fractional & Metric Tube to NPT thread
page- 40



Butt Weld Pipe Connector
Fractional & Metric Tube to pipe
page- 41



Butt Weld Pipe Elbow
Fractional Tube to pipe
page- 41



Socket Weld Tube Connector
Fractional & Metric Tube to Tube
page- 42



Reducer
Fractional & Metric Tube
page- 43



Bulkhead Reducer
Fractional & Metric Tube
page- 44



Male Adapter
Fractional & Metric Tube to
NPT thread & ISO tapered pipe thread
page- 45 & 46



Male Adapter
Fractional & Metric Tube to
ISO parallel thread
page- 47



O Seal Male Adapter
Fractional Tube to
Male Straight Thread
page- 47

CONTENTS



Reducing Union
Fractional & Metric Tube
page- 13



Reducing Union Tee
Fractional & Metric Tube
page- 17



Bulk Head Male Connector
Fractional & Metric Tube to NPT thread
page- 25



Male Branch Tee
Fractional & Metric Tube to NPT thread
page- 31



Female Elbow
Fractional & Metric Tube to NPT thread
page- 38 & 39



Socket Weld Tube Elbow
Fractional & Metric Tube to tube
page- 42



Female Adapter
Fractional & Metric Tube to
NPT thread & ISO tapered pipe thread
page- 48 & 49



Female Manometer Adapter
Fractional & Metric Tube to
ISO parallel thread (gauge)
page- 49

Fluid Control® Double Ferrule Tube Fittings

Checklist For Excellence In Tube Fittings

Tube Selection

- Tube Hardness
- Tubing Wall Thickness
- Tubing For Gas Service
- Tube Handling

Tube Specification

Thread Specification

Technical Specification To Which Fitting Perform

Assembly

Pre-swaging

Fluid Controls Gap Inspection Gauges

Ordering Codes

TUBING SELECTION

Proper selection, handling, installation of tubing when combined with the proportion of the Fluid Controls® Double Ferrule Tube fittings is essential to reliable tubing systems. Although Fluid Controls® Private Limited is not a tubing manufacturer or supplier, we feel it is our duty to impress on our customers the vital importance of careful selection of high quality tubing in order to install safe and leak free systems. Fluid Controls® will be happy to assist in the selection of such tubes to our customers when requested.

Selections of tubes are based on the material, hardness, wall thickness and surface finish. The ASTM specifications for various tubes cover material, hardness and wall thickness but do not give details on the surface finish.

For example, ASTM A 269, one of the most widely used specifications reads as follows in clause 14.1 under the title "FINISH".

Finished tubes shall be reasonably straight and have smooth ends free from burrs. They shall be free from injurious defects and shall have a workman like finish. Minor defects may be removed by grinding provided the wall thickness is not decreased to less than that permitted in clause 13".

The ASTM standard is silent on the surface finish which is required to be smooth and free from any scratches, axial or circumferential which will allow leakage paths along the joints.

We give our comments below on the selections of tubes. These requirements are specified under section 3.1.9 of ASTM A 269 or section 3.1.11 of ASTM A 213

TUBING HARDNESS

Tubing must always be softer than the fitting material by using the suggested hardness of the tubes as explained in tubing specification you will ensure joints which work perfectly.

Many misunderstandings about tubing hardness are in the area of stainless steel tubing. Fluid Controls® Double Ferrule Tube Fittings made from stainless steel have been tested successfully with tubing hardness up to RB 90, the maximum hardness allowable under ASTM A213 and ASTM A269. Although such tubing hardness is permissible and Fluid Controls® Double Ferrule Fittings will perform satisfactorily on such tubing, they will not give the maximum advantage and performance for tubes of hardness above RB 80. Hence, it is suggested that when purchasing stainless steel tubes to ASTM A213 / A269, customers specify that the hardness of the tubes should not exceed RB 80. Better still, we have found that the best results are obtained where the stainless steel tubing hardness is in the range of RB 70-74. This tubing (in the RB 70-74 range) lowers installation costs because it is more easily bent and installed.

Tubing installers should be particularly careful that the full suggested one-and-a-quarter turns after snug tight be performed to ensure the proper joints. This will give the best performance. This is especially so in the case of harder tubing where higher torques is required.

We again repeat that the RB 80 maximum hardness is a suggestion for the use of Fluid Controls® Double Ferrule Fitting in stainless steel to increase the performance of the fitting. Note that if the tubing hardness exceeds RB 90, special fittings need to be ordered.

TUBING WALL THICKNESS

The allowable pressure ratings of tubing for the wide range of wall thickness are calculated from "S" values as specified by ANSI Code B 31.1. The range of tubing wall thicknesses vary from 0.028" to 0.109" in the inch OD series and 0.75 mm to 2.5 mm in the Metric OD series respectively. These wall thicknesses are generally preferred for tube sizes up to 1" OD and 25mm OD in the two systems respectively. For higher tube sizes, these wall thicknesses may be increased to 0.125" or (3mm) and 0.167" or (4mm) in the inch (metric) system respectively.

Tubing with higher wall thickness are generally not recommended as they may lead to lowering of performance and higher torque requirements to create the joint. Tubing with lower wall thicknesses are also not recommended as there is a possibility of collapse of the tube.

Fluid Controls® will be happy to provide customers with working pressure ratings as per ANSI Code B31.1 for various wall thicknesses in the above mentioned ranges for inch and metric size tubing.

TUBING FOR GAS SERVICE

For the greatest safety factor against surface defects in any gas system it is recommended that the wall thickness employed be not less than that shown in the table below;

Tube O.D	Suggested Minimum Wall Thickness	Tube O.D	Suggested Minimum Wall Thickness
1/16"	0.028"	3/4"	0.062"
1/8"	0.028"	7/8"(20mm)	0.073"
1/4"(6mm)	0.028"	1"(25mm)	0.083"
5/16"(8mm)	0.035"	1-1/4"	0.104"
3/8"(10mm)	0.035"	1-1/2"	0.125"
1/2"(12mm)	0.041"	2"	0.167"
5/8"(16mm)	0.052"		

Light gases such as helium, hydrogen, nitrogen, etc have very small molecules which can escape through even the minutest leak path created by surface defect on the tubing. As the tube OD increases, so does the likelihood of a scratch or other surface defect interfering with proper sealing.

The most successful connection for gas service will occur if all the installation instructions are carefully followed and the heavier permissible wall thickness of tubing are selected. A heavy wall thickness resists ferrule action more than a thin wall thickness allowing the ferrules to coin out minor surface in perfection. A thin wall tube will collapse offering little resistance to ferrule action during preparation of joints. This reduces the chances of coining out surface defects essential for gas service.

TUBING HANDLING

Scratches on tube OD are a potential source of problems in leak-tight tubing systems. Good handling practices can greatly reduce scratches and protect the good surface finish of well made tubes.

Tubing should never be dragged out of a tubing rack. Particularly in sizes 3/4" and larger, the weight of the length being pulled out is sufficient to gouge the OD if there are any burrs on the end of the tubes below it in the rack.

Tubing should never be dragged across cement, asphalt, gravel or any other surface which could scratch the surface and recreate the leakage parts.

Tube cutters or hacksaws should always be sharp, and you should not try to take too deep a cut with each turn of the cutter or with each back and forth motion of the saw blade.

Tube ends should always be deburred. This allows more easy entrance of the tube into the fitting bore and helps to assure the installer that the tubing will go all the way through the ferrules without damage to the ferrule sealing edge.

TUBING SPECIFICATION

We give below the specifications to be followed for the various tubes for use with **Fluid Controls® Double Ferrule Compression Fittings**.

CARBON STEEL TUBING

Soft, annealed carbon steel hydraulic tubing to ASTM A179, DIN 2391 or equivalent based on ultimate tensile strength of 47,000 psi and for metal temperatures not to exceed 20°C to 100°C. For higher temperature service, reducing factors for elevated temperature operation as specified in table 302.3 1A and 304.1.2 of the code for pressure piping in ANSI B31.3 should be applied.

The hardness of the tube is recommended to RB 72 or less.

The tubes should be suitable for bending and flaring and free of all surface defects and imperfections.

STAINLESS STEEL TUBING

Annealed 304 or 316 Stainless Steel tubing to ASTM A269 or ASTM A213 or equivalent, based on ultimate tensile strength of 75,000 psi and suitable for temperatures 20°C to 100°C. The hardness of these tubes is not to exceed RB 80 and is preferred in the range RB 70-74. Tubes to be suitable for bending and flaring and should be free of surface defects and imperfections.

COPPER TUBING

Annealed, soft, seamless copper tubing to ASTM B75 or ASTM B88 based on an ultimate tensile strength of 30,000 psi and for a temperature in the range of 20°C to 80°C. Maximum hardness of the tube should not exceed RB 50. Tubes preferred in the range RB 40-45.

MONEL 400 TUBING

Fully annealed Monel 400 seamless tubing conforming ASTM B165 or equivalent and based on ultimate tensile strength of 70,000 psi and for use with temperatures 20°C to 90°C.

Hardness of the tube must be RB 75 maximum and is preferred in the range RB 68-72.

These tubes should be suitable for blending and flaring and free from all surface defects and imperfections.

THREAD SPECIFICATIONS

Fluid Controls® connectors have one or more tubing end connections and the others with male or female pipe threads. There are a variety of pipe threads for which Fluid Controls® Double Ferrule Fittings are available. The most popular thread connections are the American National Pipe thread (NPT) British Standard Pipe threads (BSP) and metric threads. These threads belong to standards of individual countries as well as ISO where they have been codified. All Fluid Controls® Fittings with pipe threads or stud end threads conforming to the specifications as detailed below.

- American National Pipe Thread (NPT) : Reference specification ANSI B1.20.1 : 1983
- ISO Parallel Pipe Thread (British Standard Pipe Thread) :
Reference specifications BS 2779, ISO 228/1, DIN 259, JIS B 0202, IS 2643
- ISO Taper Pipe Thread (British Standard Pipe Taper Thread)
Reference specification BS 21, ISO 7/1, DIN 2999, JIS B0203, IS 554
- Unified National Pipe Threads: Reference specifications ANCI B1.1 : 1964

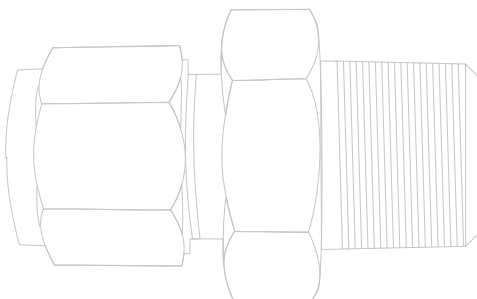
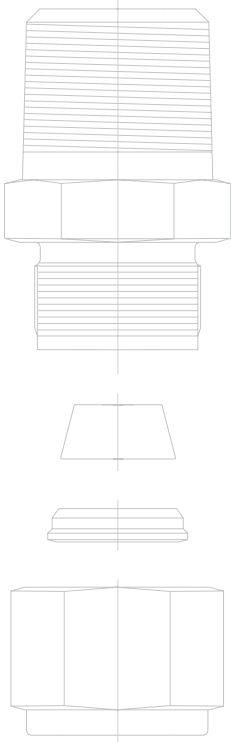

TECHNICAL SPECIFICATIONS TO WHICH FITTINGS PERFORM

There are no standards available for Double Ferrule Compression fittings. The working pressures are restricted by the maximum working pressure of the tubes to be used with the fittings. The Fluid Controls® Double Ferrule Fitting design is such that the tube will burst before the breakage of the joint. Accordingly, the working pressure outlined in the section entitled 'Allowable Pressure Ratings for Tubing will prevail as the working pressure for these fittings.

The maximum working pressure of these fittings is also restricted by the pressure ratings for the pipe end connections adopted (see section entitled 'Pressure Ratings for Pipe Ends'). The lower of the two will be the maximum working pressure for the fittings.

There are no standard specifications available for performance testing of Double Ferrule Compression Fittings. ASTM International has formulated a standard which covers a range of performance tests for off-shore and critical applications. This standard is ASTM F1387-99 (2012) for "Standard Specification for Performance of Piping and Tubing Mechanically Attached Fittings".

Fluid Controls® Private Limited has obtained ASTM F1387-99 (2012) certification for Double Ferrule Fittings. The certification is for the Mandatory and Supplementary tests specified by the standard and covers stainless steel and brass fittings.

ASTM F1387-99 Mandatory Tests:

- Performance Test
- Examination of Specimen
- Pneumatic Proof Test
- Hydrostatic Proof Test
- Impulse test
- Flexure Fatigue Test
- Tensile Test
- Burst Test
- Repeat Assembly Test
- Rotary Flexure Test

ASTM F1387-99 Supplementary Tests:

- Thermal Cycling Test
- Stress Corrosion Test
- Vibration Test
- Fire Test
- Elevated Temperature Test
- Torsion Test

Details of individual tests and copies of our certificates are available upon request or can be downloaded from our website www.fluidcontrols.com

ASSEMBLY

FLUID CONTROLS® DOUBLE FERRILE FITTINGS come to you completely assembled, finger-tight. They are ready for immediate use. Dis-assembly before use can result in dirt or foreign material getting into the fitting and causing leaks.

FLUID CONTROLS® DOUBLE FERRILE FITTINGS are installed in three easy steps.



Step 1

Insert the tubing into the FLUID CONTROLS® TUBE FITTING. Make sure that the tubing rests firmly on the shoulders of the fitting and that the nut is snug tight, in this position the tube does not rotate by hand.

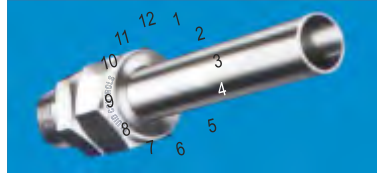

Step 2

Before tightening the FLUID CONTROLS® nut, scribe the nut at the 6.00 o'clock position

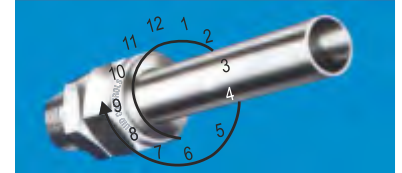

Step 3

Now while holding the fitting body steady with a backup wrench, tighten the nut one-and-one quarter turns*. Watch the scribe mark, make one complete revolution and continue to the 9.00 o'clock position.*For 1/8", 3/16", 3 & 4 mm size tube fittings, only 3/4 turns from finger-tight is necessary the joint is now complete.

HIGH PRESSURE APPLICATIONS, HIGH SAFETY FACTOR SYSTEMS

Due to the variation of tubing diameters, a common starting point is desirable. Therefore, use a wrench to snug up the nut until the tubing will not turn (by hand) in the fitting. Now tighten the nut one-and-one quarter turns and the fitting is ready to hold pressure well above the working pressure of the tubing.

RE-TIGHTENING INSTRUCTIONS

Connections can be disconnected and re-tightened many, many times and the same reliable, leak-proof seal obtained every time the reconnection is made.

PRE-SWAGING

When FLUID CONTROLS® TUBE FITTINGS are to be installed in cramped quarters or overhead where ladders must be used. It is sometimes found advantageous to use a pre-swaging tool on the tubing in an open ground area, thus pre-swaging the ferrules onto the tubing. The tubing is then removed from the pre-swaging tool and the tubing (with nut and pre-swaging ferrules) can now be attached to the fitting merely by following the re-tightening instructions.

1. Assemble FLUID CONTROLS® nut and ferrules to pre-swaging tool. Insert tubing until it bottoms in the fitting body, and tighten nut one-and-one quarter turns.
2. The nut is loosened and the tubing with pre-swaged ferrules is removed from the pre-swaging tool.
3. The connection can now be made by merely snugging up the nut as described in the re-tightening instructions.

FLUID CONTROLS® Hydraulic swaging units are now available in 1/2", 5/8", 3/4" & 1" sizes for further information consult your local FLUID CONTROLS® sales and service representative.

FLUID CONTROLS GAP INSPECTION GAUGES

FLUID CONTROLS® GAP INSPECTION GAUGES are designed to assure the installer or inspector that a fitting has been sufficiently pulled up. They are particularly applicable to systems where fittings are to be tightened in difficult or inaccessible locations or systems where in sufficient pull-up could cause potentially dangerous or expensive consequences.

FLUID CONTROLS® GAP INSPECTION GAUGES are inserted between the nut and body of a tube fitting after pull-up. If the GAP INSPECTION GAUGE will fit in the gap between the nut and body hex, the fitting nut has not been tightened sufficiently.

NOTE:

Fluid Controls® has a continuous and dynamic research and development program for the development of fittings in different materials, higher pressures and temperatures. The dimensions and information given in the catalog are subject to change without notice as a result of the findings in these programs.

ORDERING CODES

INCH SIZE TUBING

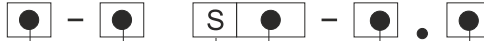

Tube O.D. in multiples of 1/16"	
Pipe thread size in multiples of 1/16"	
Reduced Tube O.D. in multiples of 1/16"	
Code for Double Ferrule Fittings (No symbol for conversion fittings)	
Fitting type designator	
Pipe thread specification	
NPT threads to ANSI B 1.20.1 - 1983	N
ISO parallel threads to ISO : 228/1	R
ISO taper threads to ISO : 7/1	Rx
UNF threads to ANSI B1.1 - 1964	U

Material designator	
Carbon Steel	CS
Brass	b
304 or 304L Stainless Steel	S/SL
316 or 316L Stainless Steel	SS/SSL
Monel	M
Titanium	Ti

METRIC SIZE TUBING



Code for Double Ferrule Fittings (No symbol for conversion fittings)	
Fitting type designator	
Tube O.D. in mm	
Pipe thread size in multiples of 1/16"	
Pipe thread specification	
NPT threads to ANSI B1.20.1 - 1983	N
ISO parallel threads to ISO : 221/1	R
ISO taper threads to ISO : 7/1	Rx
UNF threads to ASA B1 - 1964	U

Material designator	
Carbon Steel	
Brass	b
304 or 304L Stainless Steel	S/SL
316 or 316L Stainless Steel	SS/SSL
Monel	M
Titanium	Ti

FITTING TYPE DESIGNATOR

ITEM	DESIGNATOR
Front Ferrule	ff
Back Ferrule	fb
Coupling Cap	n
Tube End Closure	PC
Fitting End Closure	FC
Union	C
Reducing Union	R
Bulkhead Union	CB
Bulkhead Reducing Union	CRB
Union Elbow	E
Union Tee	T
Reducing Union Tee	TR
Cross	K
Reducing Cross	KR
Male Connector	CM
Bulkhead Male Connector	CMB
O - Seal Male Connector	CO
45° Male Elbow	EM / 45
Positionable Male Elbow	Esw
Male Run Tee	TRM
Male Branch Tee	TBM
Positionable Male Run Tee	TRsw
Positionable Male Branch Tee	TBsw
Socket Weld Tube Connector	SC-SW
Socket Weld Tube Elbow	SE - SW
Butt Weld Pipe Connector	SC-NB BW
Butt Weld Pipe Elbow	SE NB BW
Female Connector	CF
Bulkhead Female Connector	CFB
Female Elbow	EF
Female Run Tee	TRF
Female Branch Tee	TBF
Reducer	R
Bulkhead Reducer	RB
Male Adaptor	AM
O - Seal Male Adaptor	AMO
Female Adaptor	AF

NOTE :-

- (1) The bodies of fittings for metric tubes are provided with a Collar on the tube end side. This is only for identification purposes to differentiate from inch tube fittings.
- (2) Dimensions 'C' (in some cases 'Cx', 'F' and 'K') are measured from the Collar in the case of metric tube fittings.

FRONT FERRULE

INCH OD Tubes

T Tube OD	Fluid Controls Part No.
1/16	1 ff
1/8	2 ff
1/4	4 ff
5/16	5 ff
3/8	6 ff
1/2	8 ff
5/8	10 ff
3/4	12 ff
7/8	14 ff
1	16 ff
1.1/4	20 ff
1.1/2	24 ff
2	32 ff

METRIC OD Tubes

T Tube OD	Fluid Controls Part No.
3	ff-3
6	ff-6
8	ff-8
10	ff-10
12	ff-12
14	ff-14
15	ff-15
16	ff-16
18	ff-18
20	ff-20
22	ff-22
25	ff-25
28	ff-28
30	ff-30
32	ff-32
38	ff-38

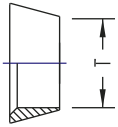

BACK FERRULE

INCH OD Tubes

T Tube OD	Fluid Controls Part No.
1/16	1 fb
1/8	2 fb
1/4	4 fb
5/16	5 fb
3/8	6 fb
1/2	8 fb
5/8	10 fb
3/4	12 fb
7/8	14 fb
1	16 fb
1.1/4	20 fb
1.1/2	24 fb
2	32 fb

METRIC OD Tubes

T Tube OD	Fluid Controls Part No.
3	fb-3
6	fb-6
8	fb-8
10	fb-10
12	fb-12
14	fb-14
15	fb-15
16	fb-16
18	fb-18
20	fb-20
22	fb-22
25	fb-25
28	fb-28
30	fb-30
32	fb-32
38	fb-38

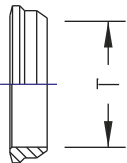

COUPLING CAP

INCH OD Tubes

T Tube OD	L	G A/F	Fluid Controls Part No.
1/16	8.0	8	1 Sn
1/8	12.0	11	2 Sn
1/4	12.7	14	4 Sn
5/16	14.0	16	5 Sn
3/8	14.5	17	6 Sn
1/2	17.5	22	8 Sn
5/8	17.5	25	10 Sn
3/4	17.5	28.5	12 Sn
7/8	17.5	32	14 Sn
1	20.6	38	16 Sn
1.1/4	31.8	50	20 Sn
1.1/2	38.0	57	24 Sn
2	52.5	76	32 Sn

METRIC OD tubes

T Tube OD	L	G A/F	Fluid Controls Part No.
3	12.0	11	Sn-3
6	12.7	14	Sn-6
8	13.5	16	Sn-8
10	15.1	19	Sn-10
12	17.5	22	Sn-12
14	17.5	25	Sn-14
15	17.5	25	Sn-15
16	17.5	25	Sn-16
18	17.5	30	Sn-18
20	17.5	32	Sn-20
22	17.5	32	Sn-22
25	20.6	38	Sn-25
28	30.6	46	Sn-28
30	32.7	50	Sn-30
32	31.8	50	Sn-32
38	38.1	57	Sn-38

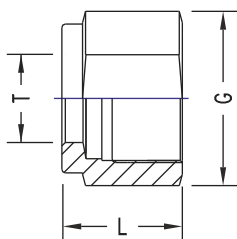

TUBE END CLOSURE

INCH OD Tubes

T Tube OD	A	C	D	F A/F	G A/F	H	Fluid Controls Part No.
1/16	13.0	11.0	8.6	11	8	11.2	1 SPC
1/8	20.0	15.3	12.7	11	11	13.5	2 SPC
1/4	23.4	17.8	15.3	14	14	16.0	4 SPC
5/16	24.4	18.5	16.3	16	16	17.0	5 SPC
3/8	25.7	19.3	16.8	17	17	18.3	6 SPC
1/2	29.2	21.8	22.9	22	22	19.0	8 SPC
5/8	30.0	21.8	24.4	24	25	19.8	10 SPC
3/4	31.5	21.8	24.4	27	28.5	21.4	12 SPC
7/8	34.0	21.8	25.9	35	32	23.9	14 SPC
1	38.4	26.4	31.2	35	38	26.2	16 SPC
1.1/4	53.3	38.9	41.2	46	50	31.2	20 SPC
1.1/2	64.5	45.2	50.0	55	57	37.4	24 SPC
2	88.6	62.7	67.6	70.0	76.0	49.3	32 SPC

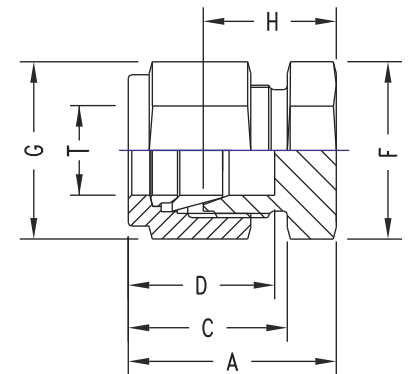

METRIC OD Tubes

T Tube OD	A	C	D	F A/F	G A/F	H	Fluid Controls Part No.
3	20.1	15.3	12.9	11	11	13.5	SPC-3
6	23.1	17.7	15.3	14	14	15.7	SPC-6
8	24.5	18.6	16.2	16	16	17.0	SPC-8
10	26.6	19.5	17.2	17	19	19.0	SPC-10
12	29.1	22.0	22.8	22	22	19.0	SPC-12
14	29.9	22.0	24.4	24	25	19.8	SPC-14
15	29.9	22.0	24.4	24	25	19.8	SPC-15
16	29.9	22.0	24.4	24	25	19.8	SPC-16
18	31.4	22.0	24.4	27	30	21.3	SPC-18
20	34.0	22.0	26.0	32	32	23.9	SPC-20
22	34.0	22.0	26.0	32	32	23.9	SPC-22
25	38.5	26.5	31.3	35	38	26.2	SPC-25
28	48.5	36.6	36.6	41	46	27.7	SPC-28
30	53.4	39.2	39.6	46	50	31.8	SPC-30
32	55.8	41.6	42.0	46	50	32.8	SPC-32
38	65.4	47.9	49.4	55	57	37.8	SPC-38



FITTING END CLOSURE

INCH OD Tubes

T Tube OD	G A/F	Fluid Controls Part No.
1/16	8	1 SFC
1/8	11	2 SFC
1/4	14	4 SFC
5/16	16	5 SFC
3/8	17	6 SFC
1/2	22	8 SFC
5/8	25	10 SFC
3/4	28.5	12 SFC
7/8	32	14 SFC
1	38	16 SFC
1.1/4	50	20 SFC
1.1/2	57	24 SFC
2	76	32 SFC

METRIC OD Tubes

T Tube OD	G A/F	Fluid Controls Part No.
3	11	SFC-3
6	14	SFC-6
8	16	SFC-8
10	19	SFC-10
12	22	SFC-12
14	25	SFC-14
15	25	SFC-15
16	25	SFC-16
18	30	SFC-18
20	32	SFC-20
22	32	SFC-22
25	38	SFC-25
28	46	SFC-28
30	50	SFC-30
32	50	SFC-32
38	57	SFC-38

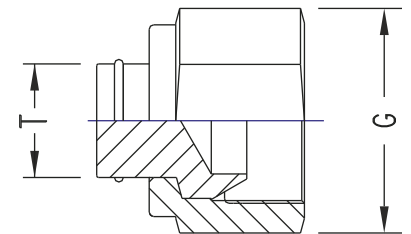

UNION

INCH OD Tubes

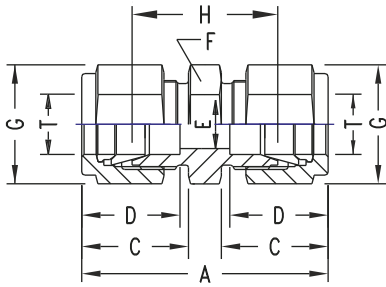

T Tube OD	A	C	D	E min.	F A/F	G A/F	H	Fluid Controls Part No.
1/16	25.1	11.0	8.6	1.3	8	8	17.5	1 SC
1/8	35.6	15.3	12.7	2.4	11	11	22.4	2 SC
1/4	40.9	17.8	15.3	4.8	14	14	26.2	4 SC
5/16	42.9	18.5	16.3	6.3	14	16	28.2	5 SC
3/8	45.0	19.3	16.8	7.1	16	17	30.2	6 SC
1/2	51.3	21.8	22.9	10.4	22	22	31.0	8 SC
5/8	52.0	21.8	24.4	12.7	24	25	31.8	10 SC
3/4	53.6	21.8	24.4	15.8	27	28.5	33.3	12 SC
7/8	55.2	21.8	25.9	18.2	30	32	34.8	14 SC
1	64.8	26.4	31.2	22.3	35	38	40.4	16 SC
1.1/4	92.2	38.9	41.2	27.6	46	50	48.0	20 SC
1.1/2	108.0	45.2	50.0	34.0	55	57	53.6	24 SC
2	149.4	62.7	67.6	46.0	70	76	74.7	32 SC

METRIC OD Tubes

T Tube OD	A	C	D	E min.	F A/F	G A/F	H	Fluid Controls Part No.
3	35.3	15.3	12.9	2.4	11	11	22.1	SC-3
6	41.0	17.7	15.3	4.8	14	14	26.2	SC-6
8	43.2	18.6	16.2	6.3	16	16	28.2	SC-8
10	46.2	19.5	17.2	7.9	17	19	31.0	SC-10
12	51.2	22.0	22.8	9.5	22	22	31.0	SC-12
14	52.0	22.0	24.4	11.1	24	25	31.0	SC-14
15	52.0	22.0	24.4	11.9	24	25	31.8	SC-15
16	52.0	22.0	24.4	12.7	24	25	31.8	SC-16
18	53.5	22.0	24.4	15.1	27	30	33.3	SC-18
20	55.0	22.0	26.0	15.9	30	32	34.8	SC-20
22	55.0	22.0	26.0	18.3	30	32	34.8	SC-22
25	65.0	26.5	31.3	21.8	35	38	40.4	SC-25
28	85.0	36.6	36.6	21.8	41	46	43.4	SC-28
30	92.7	39.2	39.6	26.2	46	50	49.5	SC-30
32	97.3	41.6	42.0	28.6	46	50	51.3	SC-32
38	113.6	47.9	49.4	33.7	55	57	58.4	SC-38

REDUCING UNION

INCH OD Tubes



T Tube OD	Tx Tube OD	A	C	Cx	D	Dx	E min.	F A/F	G A/F	Gx A/F	H	Fluid Controls Part No.
1/4	1/8	38.6	17.8	15.3	15.3	12.7	2.4	14	14	11	24.6	4-2 SCR
5/16	1/8	39.6	18.6	15.3	16.3	12.7	2.4	14	16	11	25.7	5-2 SCR
5/16	1/4	42.2	18.6	17.8	16.3	15.3	4.8	14	16	14	27.5	5-4 SCR
3/8	1/8	40.9	19.3	15.3	16.8	12.7	2.4	16	17	11	26.9	6-2 SCR
3/8	1/4	43.2	19.3	17.8	16.8	15.3	4.8	16	17	14	28.5	6-4 SCR
1/2	1/8	45.2	21.8	15.3	22.9	12.7	2.4	22	22	11	28.5	8-2 SCR
1/2	1/4	47.0	21.8	17.8	22.9	15.3	4.8	22	22	14	29.5	8-4 SCR
1/2	3/8	48.5	21.8	19.3	22.9	16.8	7.1	22	22	17	31.0	8-6 SCR
5/8	3/8	49.3	21.8	19.3	24.4	16.8	7.1	24	25	17	31.8	10-6 SCR
5/8	1/2	52.0	21.8	21.8	24.4	22.9	10.4	24	25	22	31.8	10-8 SCR
3/4	1/4	49.3	21.8	17.8	24.4	15.3	4.8	27	28.5	14	31.8	12-4 SCR
3/4	3/8	50.8	21.8	19.3	24.4	16.8	7.1	27	28.5	17	33.3	12-6 SCR
3/4	1/2	53.6	21.8	21.8	24.4	22.9	10.4	27	28.5	22	33.3	12-8 SCR
1	1/2	60.5	26.5	21.8	31.2	22.9	10.4	35	38	22	38.1	16-8 SCR
1	3/4	60.5	26.5	21.8	31.2	24.4	15.8	35	38	28.5	38.1	16-12 SCR
1.1/4	1	92.2	38.9	26.4	41.2	31.2	22.3	45	50	38	48.0	20-16 SCR
1.1/2	1.1/4	60.5	26.5	21.8	31.2	24.4	15.8	55	57	50	53.6	24-20 SCR

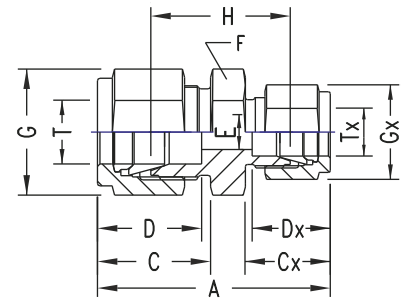

METRIC OD Tubes

T Tube OD	Tx Tube OD	A	C	Cx	D	Dx	E min.	F A/F	G A/F	Gx A/F	H	Fluid Controls Part No.
6	3	38.6	17.7	15.3	15.3	12.9	2.4	14	14	11	24.6	SCR 6-3
8	6	42.3	18.6	17.7	16.2	15.3	4.8	14	16	14	27.4	SCR 8-6
10	6	44.5	19.5	17.7	17.2	15.3	4.8	17	19	14	29.5	SCR 10-6
10	8	45.1	19.5	18.6	17.2	16.2	6.3	17	19	16	30.0	SCR 10-8
12	6	47.0	22.0	17.7	22.8	15.3	4.8	22	22	14	29.5	SCR 12-6
12	8	47.8	22.0	18.6	22.8	16.2	6.4	22	22	16	30.2	SCR 12-8
12	10	48.7	22.0	19.5	22.8	17.2	7.9	22	22	19	31.0	SCR 12-10
16	10	49.5	22.0	19.5	24.4	17.2	7.9	24	25	19	31.8	SCR 16-10
16	12	52.0	22.0	22.0	24.4	22.8	9.5	24	25	22	31.8	SCR 16-12
22	18	55.0	22.0	22.0	26.0	24.4	15.1	30	32	30	34.8	SCR 22-18
22	20	55.0	22.0	22.0	26.0	26.6	15.9	30	32	32	34.8	SCR 22-20
25	12	65.0	26.5	22.0	31.3	22.8	9.5	35	38	22	40.4	SCR 25-12
25	20	65.0	26.5	22.0	31.3	26.0	15.9	35	38	32	40.4	SCR 25-20
30	20	75.4	39.2	22.0	39.6	26.0	15.9	45	50	32	43.7	SCR 30-20
30	25	80.1	39.2	26.5	39.6	31.3	21.8	45	50	38	46.2	SCR 30-25
32	20	77.8	41.6	22.0	42.0	26.0	15.9	45	50	32	44.7	SCR 32-20
32	25	82.3	41.6	26.5	42.0	31.3	21.8	45	50	38	47.0	SCR 32-25
38	20	92.0	47.9	26.5	49.4	31.3	21.8	55	57	38	52.1	SCR 38-20
38	25	104.6	47.9	39.2	49.4	39.6	26.2	55	57	50	55.4	SCR 38-25

NOTE: The combinations shown above are representative of various possibilities. Other combinations not shown are also available. Please consult us.

BULKHEAD UNION

INCH OD Tubes

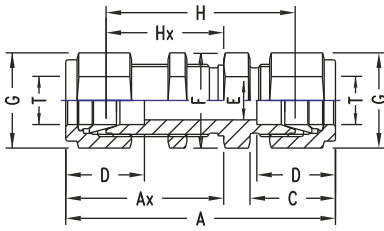

T Tube OD	A	Ax	C	D	E min.	F A/F	G A/F	H	Hx	Panel Hole Drill Size	Max. Panel Thick- ness	Fluid Controls Part No.
1/16	31.5	17.3	11.0	8.6	1.3	11	8	23.8	13.5	5.2	3.0	1 SCB
1/8	51.3	31.2	15.3	12.7	2.4	11	11	38.1	24.6	8.3	12.7	2 SCB
1/4	57.6	33.6	17.8	15.3	4.8	16	14	43.0	26.2	11.5	10.1	4 SCB
5/16	60.7	35.8	18.5	16.3	6.3	17	16	46.0	28.5	13.0	11.1	5 SCB
3/8	62.2	36.8	19.3	7.1	7.1	22	17	47.5	29.5	14.6	11.1	6 SCB
1/2	71.1	41.9	21.8	22.9	10.4	24	22	50.8	31.8	19.5	12.7	8 SCB
5/8	72.6	42.7	21.8	24.4	12.7	27	25	52.3	32.5	22.6	12.7	10 SCB
3/4	79.0	47.5	21.8	24.4	16.0	30	28.5	58.6	37.4	25.8	16.8	12 SCB
1	95.6	57.4	26.4	31.2	22.3	35	38	71.3	45.2	33.7	19.0	16 SCB
1.1/4	123.2	69.9	38.9	41.2	27.6	50	50	79.0	47.7	41.6	19.0	20 SCB
1.1/2	139.2	76.4	45.2	50.0	34.0	60	57	84.8	49.3	49.6	19.0	24 SCB
2	180.4	93.7	62.7	67.6	46.0	70	76	105.6	56.4	67.0	19.0	32 SCB

METRIC OD Tubes

T Tube OD	A	Ax	C	D	E min.	F A/F	G A/F	H	Hx	Panel Hole Drill Size	Max. Panel Thick- ness	Fluid Controls Part No.
3	51.3	31.2	15.3	12.9	2.4	14	11	38.1	24.6	8.3	12.7	SCB-3
6	57.7	33.6	17.7	15.3	4.8	16	14	42.9	26.2	11.5	10.2	SCB-6
8	61.0	36.1	18.6	16.2	6.3	17	16	46.0	28.6	13.1	11.2	SCB-8
10	63.7	37.0	19.5	17.2	7.9	22	19	48.5	29.4	16.3	11.2	SCB-10
12	71.0	41.9	22.0	22.8	9.5	24	22	50.8	31.8	19.5	12.7	SCB-12
14	72.5	42.6	22.0	24.4	11.1	27	25	52.3	32.5	22.5	12.7	SCB-14
15	72.5	42.6	22.0	24.4	11.9	27	25	52.3	32.5	22.8	12.7	SCB-15
16	72.5	42.6	22.0	24.4	12.7	27	25	52.3	32.5	22.8	12.7	SCB-16
18	78.9	47.4	22.0	24.4	15.1	30	30	58.7	37.3	26.0	16.8	SCB-18
20	84.5	53.0	22.0	26.0	15.8	35	32	64.3	42.9	29.0	19.0	SCB-20
25	95.6	57.4	26.4	31.2	22.3	35	38	71.3	45.2	33.7	19.0	SCB-25
30	123.7	70.2	39.2	39.6	26.2	50	46	80.5	48.6	40.5	19.0	SCB-30
32	128.3	72.5	41.6	42.0	27.6	50	50	82.3	49.5	42.5	19.0	SCB-32
38	144.6	79.1	47.9	49.4	33.7	60	57	89.4	51.5	50.5	19.0	SCB-38

BULKHEAD REDUCING UNION

INCH OD Tubes

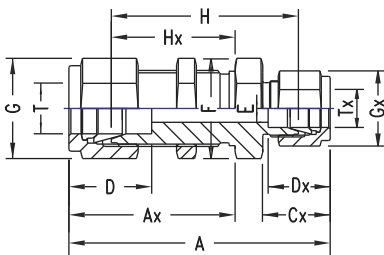

T Tube OD	T Tube OD	A	Ax	Cx	D	Dx	E min.	F A/F	G A/F	Gx A/F	H	Hx	Panel Hole Drill Size	Max. Panel Thick- ness	Fluid Controls Part No.
1/4	1/8	55.2	33.5	15.3	15.3	12.7	2.4	16	14	11	41.2	26.2	11.5	10.2	4-2 SCRB
3/8	1/4	60.7	36.6	17.8	16.8	15.3	4.8	22	17	14	46.0	29.5	14.6	11.2	6-4 SCRB
1/2	1/4	66.8	41.9	17.8	22.4	15.3	4.8	24	22	14	49.2	31.8	19.5	12.7	8-4 SCRB
1/2	3/8	66.8	41.9	17.8	22.4	16.8	7.1	24	22	17	49.2	31.8	19.5	12.7	8-6 SCRB

METRIC OD Tubes

T Tube OD	T Tube OD	A	Ax	Cx	D	Dx	E min.	F A/F	G A/F	Gx A/F	H	Hx	Panel Hole Drill Size	Max. Panel Thick- ness	Fluid Controls Part No.
6	3	56.0	33.6	17.7	15.3	12.9	2.4	16	14	11	41.2	26.2	11.5	10.2	SCRB-6-3
8	6	61.0	36.1	18.6	16.2	15.3	4.8	17	16	14	48.0	28.6	13.1	11.2	SCRB-8-6
10	6	63.7	37.0	19.5	17.2	15.3	4.8	22	19	14	48.5	29.4	16.3	11.2	SCRB-10-6
12	6	71.0	41.9	22.0	22.8	15.3	4.8	24	22	14	50.8	31.8	19.5	12.7	SCRB-12-6
12	10	71.0	41.9	22.0	22.8	17.2	7.9	24	22	17	50.8	31.8	19.5	12.7	SCRB-12-10

NOTE: The combinations shown above are representative of various possibilities. Other combinations not shown are also available. Please consult us.

UNION ELBOW

INCH OD Tubes



T Tube OD	A	C	D	E min.	F A/F	G	Hx	Fluid Controls Part No.
1/16	17.8	11.0	8.6	1.3	11	8	14.0	1 SE
1/8	22.4	15.3	12.7	2.4	11	11	15.8	2 SE
1/4	26.9	17.8	15.3	4.8	14	14	19.6	4 SE
5/16	28.7	18.5	16.3	6.3	16	16	21.3	5 SE
3/8	30.5	19.3	16.8	7.1	17	17	23.2	6 SE
1/2	36.0	21.8	22.9	10.4	22	22	25.9	8 SE
5/8	38.1	21.8	24.4	12.7	24	25	27.9	10 SE
3/4	39.9	21.8	24.4	15.8	27	28.5	29.7	12 SE
7/8	44.7	21.8	25.9	18.2	35	32	34.6	14 SE
1	49.0	26.4	31.2	22.3	35	38	36.8	16 SE
1.1/4	66.6	38.9	41.2	27.6	46	50	44.5	20 SE
1.1/2	78.0	45.2	50.0	34.0	55	57	50.8	24 SE
2	107.2	62.7	67.6	46.0	70	76	69.9	32 SE

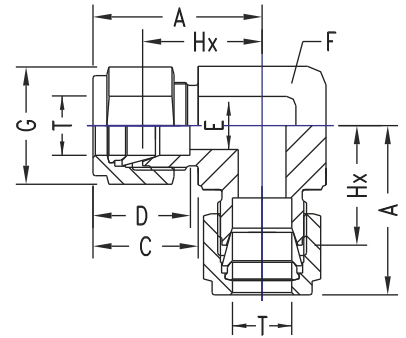

METRIC OD Tubes

T Tube OD	A	C	D	E min.	F A/F	G	Hx	Fluid Controls Part No.
3	22.3	15.3	12.9	2.4	11	11	15.7	SE-3
6	27.0	17.7	15.3	4.8	14	14	19.6	SE-6
8	28.8	18.6	16.2	6.3	16	16	21.3	SE-8
10	31.5	19.5	17.2	7.9	17	19	23.9	SE-10
12	36.0	22.0	22.8	9.5	22	22	25.9	SE-12
14	38.0	22.0	24.4	11.1	24	25	27.9	SE-14
15	38.0	22.0	24.4	11.9	24	25	27.9	SE-15
16	38.0	22.0	24.4	12.7	24	25	27.9	SE-16
18	39.8	22.0	24.4	15.1	27	30	29.7	SE-18
20	44.6	22.0	26.0	15.9	32	32	34.5	SE-20
22	44.6	22.0	26.0	18.3	32	32	34.5	SE-22
25	49.1	26.5	31.3	21.8	35	38	36.8	SE-25
28	64.0	36.6	36.6	21.8	41	46	43.5	SE-28
30	69.9	39.2	39.6	26.2	46	50	48.3	SE-30
32	72.3	41.6	42.0	28.6	46	50	49.3	SE-32
38	84.0	47.9	49.4	33.7	55	57	56.4	SE-38



BULKHEAD ELBOW

INCH OD Tubes

T Tube OD	A	Ax	Ay	C	D	E min.	F A/F	G A/F	H	Hx	Hy	Panel Hole Drill Size	Max. Panel Thick- ness	Fluid Controls Part No.
1/8	43.1	31.2	22.4	15.3	12.7	2.4	11	11	36.5	24.6	15.8	8.3	12.7	2 SEB
1/4	48.9	33.6	26.9	17.8	15.3	4.8	16	14	41.5	26.2	19.6	11.5	10.1	4 SEB
3/8	54.1	36.8	30.5	19.3	16.8	7.1	22	17	46.8	29.5	23.2	14.6	11.1	6 SEB
1/2	63.5	41.9	36.0	21.8	22.9	10.4	24	22	53.4	31.8	25.9	19.5	12.7	8 SEB
3/4	75.3	47.5	39.9	21.8	24.4	16.0	30	29	65.2	37.4	29.7	25.8	16.8	12 SEB
1	91.8	57.4	49.0	26.4	31.2	22.3	35	38	79.6	45.2	36.8	33.7	19.0	16 SEB

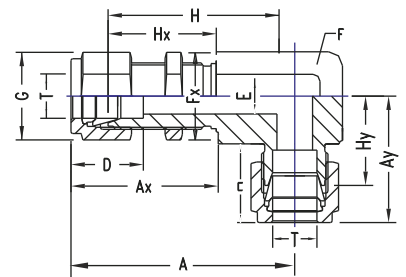

METRIC OD Tubes

T Tube OD	A	Ax	Ay	C	D	E min.	F A/F	G A/F	H	Hx	Hy	Panel Hole Drill Size	Max. Panel Thick- ness	Fluid Controls Part No.
3	43.0	31.2	22.3	15.3	12.9	2.4	14	11	36.4	24.6	15.7	8.3	12.7	SEB-3
6	49.3	33.6	27.0	17.7	15.3	4.8	16	14	41.9	26.2	19.6	11.5	10.2	SEB-6
8	52.6	36.1	28.8	18.6	16.2	6.3	17	16	45.1	28.6	21.3	13.1	11.2	SEB-8
10	56.2	37.0	31.5	19.5	17.2	7.9	22	19	48.6	29.4	23.9	16.3	11.2	SEB-10
12	63.0	41.9	36.0	22.0	22.8	9.5	24	22	52.9	31.8	25.9	19.5	12.7	SEB-12
16	66.5	42.6	38.0	22.0	24.4	12.7	27	25	56.4	32.5	27.9	22.8	12.7	SEB-16
22	85.1	53.0	44.6	22.0	26.0	18.3	35	32	75.0	42.9	34.5	29.0	19.0	SEB-20
25	91.8	57.4	49.1	26.4	31.2	22.3	35	38	79.6	45.2	36.8	33.7	19.0	SEB-25



UNION TEE

INCH OD Tubes

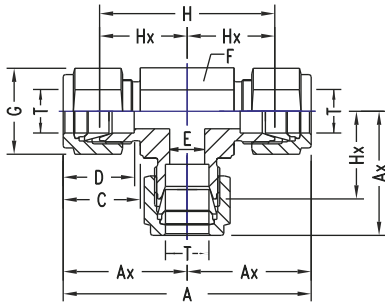

T Tube OD	A	Ax	C	D	E min.	F A/F	G A/F	H	Hx	Fluid Controls Part No.
1/16	35.6	17.8	11.0	8.6	1.3	11	8	28.0	14.0	1 ST
1/8	44.8	22.4	15.3	12.7	2.4	11	11	31.6	15.8	2 ST
1/4	53.8	26.9	17.8	15.3	4.8	14	14	39.2	19.6	4 ST
5/16	57.4	28.7	18.5	16.3	6.3	16	16	42.6	21.3	5 ST
3/8	61.0	30.5	19.3	16.8	7.1	17	17	46.4	23.2	6 ST
1/2	72.0	36.0	21.8	22.9	10.4	22	22	51.8	25.9	8 ST
5/8	76.2	38.1	21.8	24.4	12.7	24	25	55.8	27.9	10 ST
3/4	79.8	39.9	21.8	24.4	15.8	27	28.5	59.4	29.7	12 ST
7/8	89.4	44.7	21.8	25.9	18.2	35	32	69.2	34.6	14 ST
1	98.0	49.0	26.4	31.2	22.3	35	38	73.6	36.8	16 ST
1.1/4	133.2	66.6	38.9	41.2	27.6	46	50	89.0	44.5	20 ST
1.1/2	156.0	78.0	45.2	50.0	34.0	55	57	101.6	50.8	24 ST
2	214.4	107.4	62.7	67.9	46.0	70	76	139.8	69.9	32 ST

METRIC OD Tubes

T Tube OD	A	Ax	C	D	E min.	F A/F	G A/F	H	Hx	Fluid Controls Part No.
3	44.6	22.3	15.3	12.9	2.4	11	11	31.4	15.7	ST-3
6	54.0	27.0	17.7	15.3	4.8	14	14	39.2	19.6	ST-6
8	57.6	28.8	18.6	16.2	6.3	16	16	42.6	21.3	ST-8
10	63.0	31.5	19.5	17.2	7.9	17	19	47.8	23.9	ST-10
12	72.0	36.0	22.0	22.8	9.5	22	22	51.8	25.9	ST-12
14	76.0	38.0	22.0	24.4	11.1	24	25	55.8	27.9	ST-14
15	76.0	38.0	22.0	24.4	11.9	24	25	55.8	27.9	ST-15
16	76.0	38.0	22.0	24.4	12.7	24	25	55.8	27.9	ST-16
18	79.6	39.8	22.0	24.4	15.1	27	30	59.4	29.7	ST-18
20	89.2	44.6	22.0	26.0	15.9	32	32	69.0	34.5	ST-20
22	89.2	44.6	22.0	26.0	18.3	32	32	69.0	34.5	ST-22
25	98.2	49.1	26.5	31.3	21.8	35	38	73.6	36.8	ST-25
28	128.0	64.0	36.6	36.6	21.8	41	46	87.0	43.5	ST-28
30	139.8	69.9	39.2	39.6	26.2	46	50	96.6	48.3	ST-30
32	144.6	72.3	41.6	42.0	28.6	46	50	98.6	49.3	ST-32
38	168.0	84.0	47.9	49.4	33.7	55	57	112.8	56.4	ST-38

REDUCING UNION TEE

INCH OD Tubes

T Tube OD	Tx Tube OD	A	Ax	Ay	C	Cx	D	Dx	E min.	F A/F	G A/F	Gx A/F	H	Hx	Hy	Fluid Controls Part No.
3/8	1/4	61.0	30.5	29.0	19.3	17.8	16.8	15.3	4.8	16	17	14	46.2	23.1	21.6	6/6/4 STR
1/2	1/4	72.2	36.0	31.8	21.8	17.8	22.9	15.3	4.8	22	22	14	51.8	25.9	24.4	8/8/4 STR
1/2	3/8	72.2	36.0	33.3	21.8	19.3	22.9	16.8	7.1	22	22	17	51.8	25.9	25.9	8/8/6 STR
3/4	3/8	79.8	39.9	37.0	21.8	19.3	24.4	16.8	7.1	27	28.5	17	59.4	29.7	29.7	12/12/6 STR
3/4	1/2	79.8	39.9	39.9	21.8	21.8	24.4	22.9	10.4	27	28.5	22	59.4	29.7	29.7	12/12/ 8STR
1	3/8	98.0	49.0	41.9	26.4	19.3	31.2	16.8	7.1	35	38	17	73.6	36.8	34.5	16/16/A6 STR
1	1/2	98.0	49.0	44.7	26.4	22.9	31.2	21.8	10.4	35	38	22	73.6	36.8	34.5	16/16/8 STR
1	3/4	98.0	49.0	44.7	26.4	24.4	31.2	24.4	15.8	35	38	28.5	73.6	36.8	34.5	16/16/12 STR
1.1/4	1	135.6	67.8	55.1	38.9	26.4	41.2	31.2	22.3	46	50	38	91.4	45.7	42.9	20/20/16 STR
1.1/2	1	157.5	78.7	60.0	44.7	26.4	50.0	31.2	22.3	55	57	38	103.2	51.6	47.8	24/24/16 STR

INCH OD Tubes

T Tube OD	Tx Tube OD	A	Ax	Ay	C	Cx	D	Dx	E min.	F A/F	G A/F	Gx A/F	H	Hx	Hy	Fluid Controls Part No.
3/8	1/4	59.4	30.5	29.0	19.3	17.8	16.8	15.3	4.8	16	17	14	44.7	23.1	21.6	6/4/6 STR
1/2	1/4	67.7	36.0	31.7	21.8	17.8	22.9	15.3	4.8	22	22	14	50.2	25.9	24.3	8/4/8 STR
1/2	3/8	69.3	36.0	33.3	21.8	19.3	22.9	16.8	7.1	22	22	17	51.8	25.9	25.9	8/6/8 STR
3/4	3/8	77.0	39.9	37.1	21.8	19.3	24.4	16.8	7.1	27	28.5	17	59.4	29.7	29.7	12/6/12 STR
3/4	1/2	79.8	39.9	39.9	21.8	21.8	24.4	22.9	10.4	27	28.5	22	59.4	29.7	29.7	12/8/12STR
1	3/8	98.9	49.0	41.9	26.4	19.3	31.2	16.8	7.1	35	38	17	71.3	36.8	34.5	16/6/16 STR
1	1/2	93.7	49.0	44.7	26.4	21.8	31.2	21.8	10.4	35	38	22	71.3	36.8	34.5	16/8/16 STR
1	3/4	93.7	49.0	44.7	26.4	21.8	31.2	24.4	15.8	35	38	28.5	71.3	36.8	34.5	16/12/16 STR
1.1/4	1	119.6	67.8	53.0	38.9	26.4	41.2	31.2	18.2	46	50	38	85.3	45.7	40.8	20/16/20 STR
1.1/2	1	150.9	78.7	72.9	45.2	38.9	50.0	41.3	27.6	55	57	38	101.6	50.8	50.8	24/20/24 STR

INCH OD Tubes

T Tube OD	Tx Tube OD	A	Ax	Ay	C	Cx	D	Dx	E min.	F A/F	G A/F	Gx A/F	H	Hx	Hy	Fluid Controls Part No.
3/8	1/4	59.6	30.6	29.0	19.3	17.8	16.8	15.3	4.8	16	17	14	44.8	23.2	21.6	6/4/4 STR
1/2	1/4	67.7	36.0	31.7	21.8	17.8	22.9	15.3	4.8	22	22	14	50.2	25.9	24.3	8/4/4 STR
1/2	3/8	69.3	36.0	33.2	21.8	19.3	22.9	16.8	7.1	22	22	17	51.8	25.9	25.9	8/6/6 STR
3/4	3/8	77.0	38.9	37.0	21.8	19.3	24.4	16.8	7.1	27	28.5	17	59.4	29.7	29.7	12/6/6 STR
3/4	1/2	79.8	39.9	39.9	21.8	21.8	24.4	22.9	10.4	27	28.5	22	59.4	29.7	29.7	12/8/ 8STR
1	3/8	99.9	39.9	41.9	26.4	19.3	31.2	16.8	7.1	35	38	17	71.3	36.8	34.5	16/6/6 STR
1	1/2	93.7	49.0	44.7	26.4	22.9	31.2	21.8	10.4	35	38	22	71.3	36.8	34.5	16/8/8 STR
1	3/4	93.7	49.0	44.7	26.4	24.4	31.2	24.4	15.8	35	38	28.5	71.3	36.8	34.5	16/12/12 STR
1.1/4	1	122.9	67.8	55.1	38.9	26.4	41.2	31.2	22.3	46	50	38	88.6	45.7	42.9	20/16/16 STR
1.1/2	1	138.7	78.7	60.0	44.7	26.4	50.0	31.2	22.3	50	57	38	99.4	51.6	47.8	24/16/16 STR

NOTE: 1. The order of the sizes is as per the designation (1-2-3) in figure shown above.

NOTE: The combinations shown above are representative of various possibilities. Other combinations not shown are also available. Please consult us.

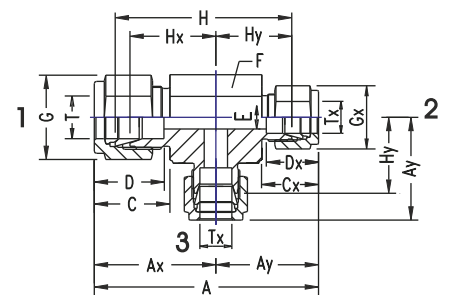
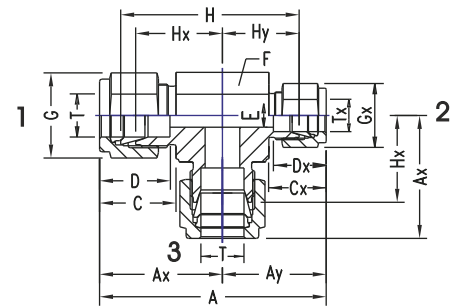
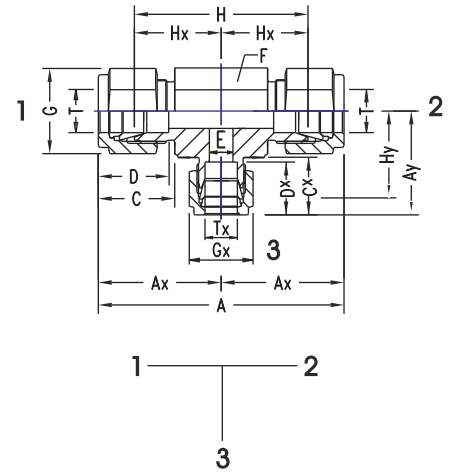

UNION CROSS

INCH OD Tubes

T Tube OD	A	Ax	C	D	E min.	F A/F	G A/F	H	Hx	Fluid Controls Part No.
1/8	44.8	22.4	15.3	12.7	2.4	11	11	31.6	15.8	2 SK
1/4	53.8	26.9	17.8	15.3	4.8	14	14	39.2	19.6	4 SK
3/8	61.0	30.5	19.3	16.8	7.1	17	17	46.4	23.2	6 SK
1/2	72.0	36.0	21.8	22.9	10.4	22	22	51.8	25.9	8 SK
3/4	79.8	39.9	21.8	24.4	15.8	27	28.5	59.4	29.7	12 SK
1	98.0	49.0	26.4	31.2	22.3	35	38	73.6	36.8	16 SK

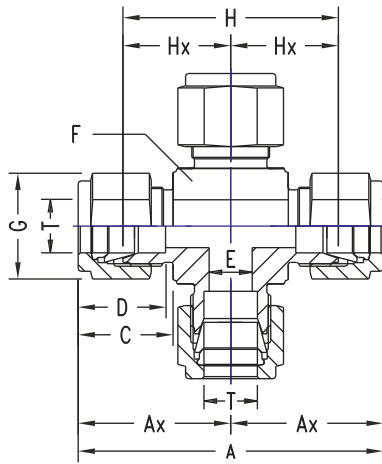

METRIC OD Tubes

T Tube OD	A	Ax	C	D	E min.	F A/F	G A/F	H	Hx	Fluid Controls Part No.
3	44.6	22.3	15.3	12.9	2.4	11	11	31.4	15.7	SK-3
6	54.0	27.0	17.7	15.3	4.8	14	14	39.2	19.6	SK-6
8	57.6	28.8	18.6	16.2	6.3	16	16	42.6	21.3	SK-8
10	63.0	31.5	19.5	17.2	7.9	17	19	47.8	23.9	SK-10
12	72.0	36.0	22.0	22.8	9.5	22	22	51.8	25.9	SK-12
16	76.0	38.0	22.0	24.4	12.7	24	25	55.8	27.9	SK-16
22	89.2	44.6	22.0	26.0	18.3	32	32	69.0	34.5	SK-22
25	98.2	49.1	26.5	31.3	21.8	35	38	73.6	36.8	SK-25

NOTE: Reducing Cross with variation in the tube sizes are available. The tube sizes are designated in the order given below.

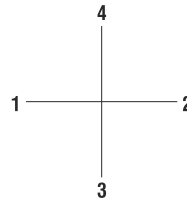

The tube sizes are indicated in the part number in the same order above.

MALE CONNECTOR

INCH OD Tubes X Male NPT Threads



T Tube OD	P NPT Male	A	B	C	D	E min.	F A/F	G A/F	H	Fluid Controls Part No.
1/16	1/16	23.9	9.6	11.0	8.6	1.3	8	8	20.0	1 SCM-N
1/16	1/8	26.2	9.6	11.0	8.6	1.3	14	8	22.4	1-2 SCM-N
1/8	1/8	30.5	9.6	15.3	12.7	2.4	11	11	23.9	2 SCM-N
1/8	1/4	35.6	14.3	15.3	12.7	2.4	14	11	29.0	2-4 SCM-N
1/4	1/8	32.8	9.6	17.8	15.3	4.8	14	14	25.4	4-2 SCM-N
1/4	1/4	37.8	14.3	17.8	15.3	4.8	14	14	30.5	4 SCM-N
1/4	3/8	38.4	14.3	17.8	15.3	4.8	19	14	31.0	4-6 SCM-N
1/4	1/2	44.7	19.1	17.8	15.3	4.8	22	14	37.4	4-8 SCM-N
5/16	1/4	38.6	14.3	18.5	16.3	6.3	14	16	31.2	5-4 SCM-N
3/8	1/8	35.3	9.6	19.3	16.8	4.8	16	17	27.9	6-2 SCM-N
3/8	1/4	39.8	14.3	19.3	16.8	7.1	16	17	32.5	6-4 SCM-N
3/8	3/8	39.8	14.3	19.3	16.8	7.1	19	17	32.5	6 SCM-N
3/8	1/2	41.2	19.1	19.3	16.8	7.1	22	17	38.9	6-8 SCM-N
1/2	1/4	43.4	14.3	21.8	22.9	7.1	22	22	33.3	8-4 SCM-N
1/2	3/8	43.4	14.3	21.8	22.9	9.6	22	22	33.3	8-6 SCM-N
1/2	1/2	49.0	19.1	21.8	22.9	10.4	22	22	38.9	8 SCM-N
1/2	3/4	50.5	19.1	21.8	22.9	10.4	27	22	40.4	8-12 SCM-N
1/2	1	57.1	23.8	21.8	22.9	10.4	35	22	47.0	8-16 SCM-N
5/8	3/8	44.2	14.3	21.8	24.4	9.6	24	25	34.0	10-6 SCM-N
5/8	1/2	49.0	19.1	21.8	24.4	10.4	24	25	38.9	10-8 SCM-N
3/4	1/2	50.5	19.1	21.8	24.4	10.4	27	28.5	40.4	12-8 SCM-N
3/4	3/4	50.5	19.1	21.8	24.4	15.8	27	28.5	40.4	12 SCM-N
3/4	1	57.1	23.8	21.8	24.4	15.8	35	28.5	47.0	12-16 SCM-N
7/8	3/4	50.5	19.1	21.8	26.0	15.8	30	32	40.4	14-12 SCM-N
1	1/2	57.4	19.1	26.4	31.2	10.4	35	38	45.2	16-8 SCM-N
1	3/4	57.4	19.1	26.4	31.2	15.8	35	38	45.2	16-12 SCM-N
1	1	62.2	23.8	26.4	31.2	22.3	35	38	50.0	16 SCM-N
1.1/4	1	77.2	23.8	38.9	41.2	22.3	46	50	55.2	20-16 SCM-N
1.1/4	1.1/4	77.2	23.8	38.9	41.2	27.6	46	50	55.2	20 SCM-N
1.1/2	1.1/2	88.9	26.2	45.2	50.0	34.0	55	57	61.7	24 SCM-N
2	2	113.5	26.9	62.7	67.6	46.0	70	76	76.2	32 SCM-N

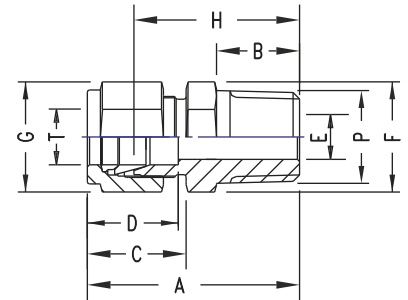

INCH OD Tubes X Male ISO * Tapered Pipe Threads

T Tube OD	P ISO Male	A	B	C	D	E min.	F A/F	G A/F	H	Fluid Controls Part No.
1/8	1/8	30.5	9.6	15.3	12.7	2.4	11	11	23.9	2 SCM-Rx
1/8	1/4	35.6	14.3	15.3	12.7	2.4	14	11	29.0	2-4 SCM-N-Rx
1/4	1/8	32.8	9.6	17.8	15.3	4.8	14	14	25.4	4-2 SCM-Rx
1/4	1/4	37.8	14.3	17.8	15.3	4.8	14	14	30.1	4 SCM-Rx
1/4	3/8	38.4	14.3	17.8	15.3	4.8	19	14	31.0	4-6 SCM-Rx
1/4	1/2	44.7	19.1	17.8	15.3	4.8	22	14	37.4	4-8 SCM-Rx
3/8	1/8	35.3	9.6	19.3	16.8	4.8	16	17	27.9	6-2 SCM-Rx
3/8	1/4	39.8	14.3	19.3	16.8	7.1	16	17	32.5	6-4 SCM-Rx
3/8	3/8	39.8	14.3	19.3	16.8	7.1	19	17	32.5	6 SCM-Rx
3/8	1/2	41.2	19.1	19.3	16.8	7.1	22	17	38.9	6-8 SCM-Rx
1/2	1/4	43.4	14.3	21.8	22.9	7.1	22	22	33.3	8-4 SCM-Rx
1/2	3/8	43.4	14.3	21.8	22.9	9.6	22	22	33.3	8-6 SCM-Rx
1/2	1/2	49.0	19.1	21.8	22.9	10.4	22	22	38.9	8 SCM-Rx
3/4	3/4	50.5	19.1	21.8	24.4	15.8	27	28.5	40.4	12 SCM-Rx
1	1	62.2	23.8	26.4	31.2	22.3	35	38	50.0	16 SCM-Rx
1.1/4	1	77.2	23.8	38.9	41.2	22.3	46	50	55.2	20-16 SCM-Rx
1.1/4	1.1/4	77.2	23.8	38.9	41.2	27.6	46	50	55.2	20 SCM-Rx
1.1/2	1.1/2	88.9	26.2	45.2	50.0	34.0	55	57	61.7	24 SCM-Rx

* Reference Specifications : BS 21 : ISO 7/1 : JIS B 0203 : DIN 2999 : IS 554

NOTE: The combination of tube OD and male threads are indicative of popular sizes. Other combinations, not shown, are available. Please Consult us.

BORED - THROUGH CONNECTORS available in all these sizes. Add suffix "BT" to the above part numbers to designate bored - through male connector.

MALE CONNECTOR

METRIC OD Tubes x Male NPT Threads

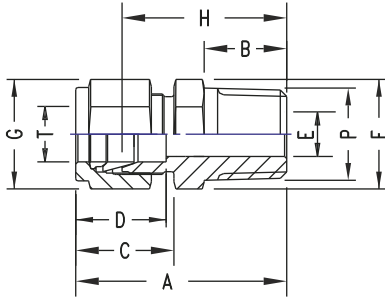

T Tube OD	P NPT Male	A	B	C	D	E min.	F A/F	G A/F	H	Fluid Controls Part No.
3	1/8	30.5	9.6	15.3	12.9	2.4	11	11	23.9	SCM 3-2N
3	1/4	35.6	14.3	15.3	12.9	2.4	14	11	29.0	SCM 3-4N
6	1/8	32.8	9.6	17.7	15.3	4.8	14	14	25.4	SCM 6-2N
6	1/4	37.9	14.3	17.7	15.3	4.8	14	14	30.5	SCM 6-4N
6	3/8	38.4	14.3	17.7	15.3	4.8	19	14	31.0	SCM 6-N
6	1/2	44.7	19.1	17.7	15.3	4.8	22	14	37.3	SCM 6-8N
8	1/8	34.2	9.6	18.6	16.2	4.8	14	16	26.7	SCM 8-2N
8	1/4	38.7	14.3	18.6	16.2	6.3	14	16	31.2	SCM 8-4N
8	3/8	39.3	14.3	18.6	16.2	6.3	19	16	31.8	SCM 8-6N
8	1/2	45.6	19.1	18.6	16.2	6.3	22	16	38.1	SCM 8-N
10	1/8	36.3	9.6	19.5	17.2	4.8	17	19	28.7	SCM 10-2N
10	1/4	40.9	14.3	19.5	17.2	7.9	19	19	33.3	SCM 10-4N
10	3/8	40.9	14.3	19.5	17.2	7.9	19	19	33.3	SCM 10-6N
10	1/2	46.5	19.1	19.5	17.2	7.9	22	19	38.9	SCM 10-8N
12	1/4	43.4	14.3	22.0	22.8	7.1	22	22	33.3	SCM 12-4N
12	3/8	43.4	14.3	22.0	22.8	9.5	22	22	33.3	SCM 12-6N
12	1/2	49.0	19.1	22.0	22.8	9.5	22	22	38.9	SCM 12-8N
12	3/4	50.5	19.1	22.0	22.8	9.5	27	22	40.4	SCM 12-N
12	1	57.1	23.8	22.0	22.8	9.5	35	22	47.0	SCM 12-16N
14	1/4	44.1	14.3	22.0	24.4	7.1	24	25	34.0	SCM 14-4N
14	3/8	44.1	14.3	22.0	24.4	9.5	24	25	34.0	SCM 14-6N
14	1/2	49.0	19.1	22.0	24.4	11.1	24	25	38.9	SCM 14-8N
15	1/2	49.0	19.1	22.0	24.4	11.9	24	25	38.9	SCM 15 8N
16	3/8	44.1	14.3	22.0	24.4	9.5	24	25	34.0	SCM 16-6N
16	1/2	49.0	19.1	22.0	24.4	11.9	24	25	38.9	SCM 16-8N
16	3/4	50.5	19.1	22.0	24.4	12.7	27	25	40.4	SCM 16-12N
18	1/2	50.5	19.1	22.0	24.4	11.9	27	30	40.4	SCM 18-8N
18	3/4	50.5	19.1	22.0	24.4	15.1	27	30	40.4	SCM 18-12N
20	1/2	52.3	19.1	22.0	26.0	11.9	30	32	42.2	SCM 20-8N
20	3/4	52.3	19.1	22.0	26.0	15.9	30	32	42.2	SCM 20-12N
22	3/4	52.3	19.1	22.0	26.0	15.9	30	32	42.2	SCM 22-12N
22	1	57.1	23.8	22.0	26.0	18.3	35	32	47.0	SCM 22 16N
25	1/2	57.5	19.1	26.5	31.3	11.9	35	38	45.2	SCM 25- 8N
25	3/4	57.5	19.1	26.5	31.3	15.8	35	38	45.2	SCM 25-12N
25	1	62.3	23.8	26.5	31.3	21.8	35	38	50.0	SCM 25-16N
28	1	72.4	23.8	36.6	36.6	21.8	41	46	51.6	SCM 28-16N
28	1.1/4	73.1	23.8	36.6	36.6	21.8	46	46	52.3	SCM 28-20N
30	1.1/4	77.2	23.8	39.2	39.6	26.2	46	50	55.6	SCM 30-20N
32	1.1/4	79.6	23.8	41.6	42.0	28.6	46	50	56.6	SCM 32-20N
38	1.1/2	96.6	26.2	47.9	49.4	33.7	55	57	64.0	SCM 38-24N

Bored-Through Fittings for Thermocouples



To order, add BT to the desired Fluid Controls Male Connector Part Number : 8 SCM - N. BT
 Example : Bored Through Connection 1/2" OD x 1/2" NPT (M) with 1/2" OD through bore has part number.

MALE CONNECTOR

METRIC OD Tubes x Male ISO* Tapered Pipe Thread

T Tube OD	P ISO Male	A	B	C	D	E min.	F A/F	G A/F	H	Fluid Controls Part No.
3	1/8	30.5	9.6	15.3	12.9	2.4	11	11	23.9	SCM 3-2 Rx
3	1/4	35.6	14.3	15.3	12.9	2.4	14	11	29.0	SCM 3-4 Rx
6	1/8	32.8	9.6	17.7	15.3	4.8	14	14	25.4	SCM 6-2 Rx
6	1/4	37.9	14.3	17.7	15.3	4.8	14	14	30.5	SCM 6-4 Rx
6	3/8	38.4	14.3	17.7	15.3	4.8	19	14	31.0	SCM 6 Rx
6	1/2	44.7	19.1	17.7	15.3	4.8	22	14	37.3	SCM 6-8 Rx
8	1/8	34.2	9.6	18.6	16.2	4.8	14	16	26.7	SCM 8-2 Rx
8	1/4	38.7	14.3	18.6	16.2	6.3	14	16	31.2	SCM 8-4 Rx
8	3/8	39.3	14.3	18.6	16.2	6.3	19	16	31.8	SCM 8-6 Rx
8	1/2	45.6	19.1	18.6	16.2	6.3	22	16	38.1	SCM 8 Rx
10	1/8	36.3	9.6	19.5	17.2	4.8	17	19	28.7	SCM 10-2 Rx
10	1/4	40.9	14.3	19.5	17.2	7.9	19	19	33.3	SCM 10-4 Rx
10	3/8	40.9	14.3	19.5	17.2	7.9	19	19	33.3	SCM 10-6 Rx
10	1/2	46.5	19.1	19.5	17.2	7.9	22	19	38.9	SCM 10-8 Rx
12	1/4	43.4	14.3	22.0	22.8	7.1	22	22	33.3	SCM 12-4 Rx
12	3/8	43.4	14.3	22.0	22.8	9.5	22	22	33.3	SCM 12-6 Rx
12	1/2	49.0	19.1	22.0	22.8	9.5	22	22	38.9	SCM 12-8 Rx
12	3/4	50.5	19.1	22.0	22.8	9.5	27	22	40.4	SCM 12 Rx
12	1	57.1	23.8	22.0	22.8	9.5	35	22	47.0	SCM 12-16 Rx
14	3/8	44.1	14.3	22.0	24.4	9.5	24	25	34.0	SCM 14-6 Rx
14	1/2	49.0	19.1	22.0	24.4	11.1	24	25	38.9	SCM 14-8 Rx
15	1/2	49.0	19.1	22.0	24.4	11.9	24	25	38.9	SCM 15 8 Rx
16	3/8	44.1	14.3	22.0	24.4	9.5	24	25	34.0	SCM 16-6 Rx
16	1/2	49.0	19.1	22.0	24.4	11.9	24	25	38.9	SCM 16-8 Rx
16	3/4	50.5	19.1	22.0	24.4	12.7	27	25	40.4	SCM 16-12 Rx
18	1/2	50.5	19.1	22.0	24.4	11.9	27	30	40.4	SCM 18-8 Rx
18	3/4	50.5	19.1	22.0	24.4	15.1	27	30	40.4	SCM 18-12 Rx
20	1/2	52.3	19.1	22.0	26.0	11.9	30	32	42.2	SCM 20-8 Rx
20	3/4	52.3	19.1	22.0	26.0	15.9	30	32	42.2	SCM 20-12 Rx
22	3/4	52.3	19.1	22.0	26.0	15.9	30	32	42.2	SCM 22-12 Rx
22	1	57.1	23.8	22.0	26.0	18.3	35	32	47.0	SCM 22 16 Rx
25	1/2	57.5	19.1	26.5	31.3	11.9	35	38	45.2	SCM 25- 8 Rx
25	3/4	57.5	19.1	26.5	31.3	15.8	35	38	45.2	SCM 25-12 Rx
25	1	62.3	23.8	26.5	31.3	21.8	35	38	50.0	SCM 25-16 Rx
28	1	72.4	23.8	36.6	36.6	21.8	41	46	51.6	SCM 28-16 Rx
28	1.1/4	73.1	23.8	36.6	36.6	21.8	46	46	52.3	SCM 28-20 Rx
30	1.1/4	77.2	23.8	39.2	39.6	26.2	46	50	55.6	SCM30-20 RX
32	1.1/4	79.6	23.8	41.6	42.0	28.6	46	50	56.6	SCM32-20 Rx
38	1.1/2	96.6	26.2	47.9	49.4	33.7	55	57	64.0	SCM 38-24 Rx

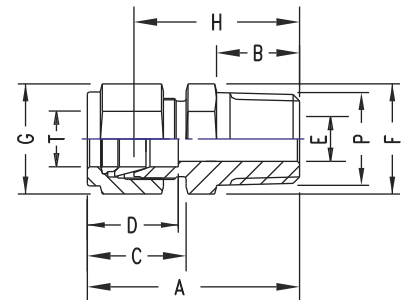

* Reference Specifications : BS 21: ISO 7/1 : JIS B 0203 : DIN 2999 : IS 554

Bored-Through Fittings for Thermocouples



To order, add BT to the desired Fluid Controls Male Connector Part Number : 8 SCM - Rx. BT

Example : Bored Through Connection 1/2" OD x 1/2" ISO Tapered Male Pipe Thread 1/2" OD through bore has part number.

MALE CONNECTOR

INCH OD Tubes x Male ISO* Parallel Threads - RP

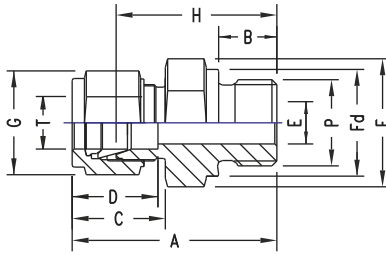

T Tube OD	P ISO Male	A	B	C	D	E min.	F A/F	Fd	G A/F	H	Fluid Controls Part No.
1/8	1/8	30.0	7.1	15.3	12.7	2.4	14	13.7	11	23.4	2 SCM-Rp
1/8	1/4	35.3	11.2	15.3	12.7	2.4	19	18.0	11	28.7	2-4 SCMN-Rp
1/4	1/8	32.3	7.1	17.8	15.3	4.8	14	13.7	14	24.9	4-2 SCM-Rp
1/4	1/4	37.6	11.2	17.8	15.3	4.8	19	18.0	14	30.2	4 SCM-Rp
1/4	3/8	38.9	11.2	17.8	15.3	4.8	22	21.8	14	31.5	4-6 SCM-Rp
1/4	1/2	44.7	14.2	17.8	15.3	4.8	27	26.0	14	37.4	4-8 SCM-Rp
3/8	1/4	39.2	11.2	19.3	16.8	5.8	19	18.0	17	31.8	6-4 SCM-Rp
3/8	3/8	40.4	11.2	19.3	16.8	7.1	22	21.8	17	33.0	6 SCM-Rp
3/8	1/2	46.3	14.2	19.3	16.8	7.1	27	26.0	17	38.9	6-8 SCM-Rp
1/2	1/4	42.7	11.2	21.8	22.9	5.8	22	18.0	22	32.5	8-4 SCM-Rp
1/2	3/8	43.2	11.2	21.8	22.9	7.9	22	21.8	22	33.0	8-6 SCM-Rp
1/2	1/2	49.0	14.2	21.8	22.9	10.4	27	26.0	22	38.9	8 SCM-Rp
1/2	3/4	52.8	15.7	21.8	22.9	10.4	35	32.0	22	42.7	8-12 SCM-Rp
3/4	1/2	49.0	14.2	21.8	24.4	11.9	27	26.0	28.5	38.9	12-8 SCM-Rp
3/4	3/4	52.8	15.7	21.8	24.4	15.8	35	32.0	28.5	42.7	12 SCM-Rp
3/4	1	55.4	18.3	21.8	24.4	15.8	41	39.0	28.5	45.6	12-16 SCM-Rp
1	1/2	55.9	14.2	26.4	31.2	11.9	35	26.0	38	43.7	16-8 SCM-Rp
1	3/4	57.5	15.7	26.4	31.2	15.8	35	32.0	38	45.2	16-12 SCM-Rp
1	1	60.0	18.3	26.4	31.2	19.8	41	39.0	38	47.8	16 SCM-Rp
1.1/4	1.1/4	78.9	19.8	38.9	41.2	25.0	50	49.0	50	55.9	20 SCM-Rp
1.1/2	1.1/2	90.8	22.1	45.2	50.0	31.8	60	54.7	57	63.2	24 SCM-Rp

METRIC OD Tubes x Male ISO* Parallel Threads - RP

T Tube OD	P ISO Male	A	B	C	D	E min.	F A/F	Fd A/F	G	H	Fluid Controls Part No.
3	1/8	30.0	7.1	15.3	12.9	2.4	14	13.8	11	23.4	SCM 3-2Rp
3	1/4	35.3	11.2	15.3	12.9	2.4	19	18.0	11	28.7	SCM 3-4Rp
6	1/8	32.3	7.1	17.7	15.3	4.8	14	13.8	14	24.9	SCM 6-2Rp
6	1/4	37.6	11.2	17.7	15.3	4.8	19	18.0	14	30.2	SCM 6-4Rp
6	3/8	38.9	11.2	17.7	15.3	4.8	22	21.8	14	31.5	SCM 6-Rp
6	1/2	44.7	14.2	17.7	15.3	4.8	27	26.0	14	37.3	SCM 6-8Rp
8	1/8	33.2	7.1	18.6	16.2	4.0	14	13.8	16	25.7	SCM 8-2Rp
8	1/4	38.5	11.2	18.6	16.2	6.4	19	18.0	16	31.0	SCM 8-4Rp
8	3/8	39.8	11.2	18.6	16.2	6.4	22	21.8	16	32.3	SCM 8-6Rp
8	1/2	45.6	14.2	18.6	16.2	6.4	27	26.0	16	38.1	SCM 8-Rp
10	1/4	39.4	11.2	19.5	17.2	5.9	19	18.0	19	31.8	SCM 10-4Rp
10	3/8	40.6	11.2	19.5	17.2	7.6	22	21.8	19	33.0	SCM 10-6Rp
10	1/2	46.5	14.2	19.5	17.2	7.9	27	26.0	19	38.9	SCM 10-8Rp
12	1/4	42.6	11.2	22.0	22.8	5.9	22	18.0	22	32.5	SCM 12-4Rp
12	3/8	43.1	11.2	22.0	22.8	7.9	22	21.8	22	33.0	SCM 12-6Rp
12	1/2	49.0	14.2	22.0	22.8	9.5	27	26.0	22	38.9	SCM 12-8Rp
12	3/4	52.8	15.7	22.0	22.8	9.5	35	32.0	22	42.7	SCM 12Rp
16	3/8	43.9	11.2	22.0	24.4	7.9	24	21.8	25	33.8	SCM 16-6Rp
16	1/2	49.0	14.2	22.0	24.4	11.9	27	26.0	25	38.9	SCM 16-8Rp
20	1/2	50.5	14.2	22.0	26.0	11.9	30	26.0	28.5	40.4	SCM 20-8Rp
20	3/4	52.3	15.7	22.0	26.0	15.9	35	32.0	28.5	42.7	SCM 22-12Rp
22	3/4	52.3	15.7	22.0	26.0	15.9	35	32.0	32	42.7	SCM 20-16Rp
22	1	55.3	18.3	22.0	26.0	18.3	41	39.0	32	45.2	SCM 25-12Rp
25	3/4	57.5	15.7	26.5	31.3	15.9	35	32.0	38	45.2	SCM 20-16Rp
25	1	60.1	18.3	26.5	31.3	19.8	41	39.0	38	47.8	SCM 20-12Rp
28	1	70.1	18.3	36.6	36.6	19.8	41	39.0	46	49.3	SCM 28-16Rp
30	1.1/4	76.5	19.8	39.2	39.6	25.0	50	49.0	50	54.9	SCM 30-20Rp
32	1.1/4	78.9	19.8	41.6	42.0	25.0	50	49.0	50	55.9	SCM 32-20Rp
38	1.1/2	90.8	22.1	47.9	49.4	31.8	55	54.7	57	63.2	SCM 38-24Rp

NOTE: The ISO parallel Thread System RP shown on this page does not create pressure tight seal against the threads. The seal is made by metal to metal contact against the female part. A soft metal (usually annealed copper) gasket between the fitting and the part face.

BORED - THROUGH FITTINGS FOR THERMOCOUPLE ARE AVAILABLE WITH ISO PARALLEL MALE THREADS. Add suffix "BT" to the above part numbers above.

* Reference Specifications : BS 2779 : ISO 228/1 : JIS B 0202 : DIN-ISO 228/1

MALE CONNECTOR

INCH OD Tubes x Male ISO* Parallel Threads - RS

T Tube OD	P ISO Male	A	B	C	D	E min.	F A/F	Fd	G A/F	H	Fluid Controls Part No..
1/8	1/8	30.0	7.1	15.3	12.7	2.4	14	13.7	11	23.4	2 SCM-Rs
1/8	1/4	35.3	11.2	15.3	12.7	2.4	19	18.0	11	28.7	2-4 SCMN-Rs
1/4	1/8	32.3	7.1	17.8	15.3	4.8	14	13.7	14	24.9	4-2 SCM-Rs
1/4	1/4	37.6	11.2	17.8	15.3	4.8	19	18.0	14	30.2	4 SCM-Rs
1/4	3/8	38.9	11.2	17.8	15.3	4.8	22	21.8	14	31.5	4-6 SCM-Rs
1/4	1/2	44.7	14.2	17.8	15.3	4.8	27	26.0	14	37.4	4-8 SCM-Rs
3/8	1/4	39.2	11.2	19.3	16.8	5.8	19	18.0	17	31.8	6-4 SCM-Rs
3/8	3/8	40.4	11.2	19.3	16.8	7.1	22	21.8	17	33.0	6 SCM-Rs
3/8	1/2	46.3	14.2	19.3	16.8	7.1	27	26.0	17	38.9	6-8 SCM-Rs
1/2	1/4	42.7	11.2	21.8	22.9	5.8	22	18.0	22	32.5	8-4 SCM-Rs
1/2	3/8	43.2	11.2	21.8	22.9	7.9	22	21.8	22	33.0	8-6 SCM-Rs
1/2	1/2	49.0	14.2	21.8	22.9	10.4	27	26.0	22	38.9	8 SCM-Rs
1/2	3/4	52.8	15.7	21.8	22.9	10.4	35	32.0	22	42.7	8-12 SCM-Rs
3/4	1/2	49.0	14.2	21.8	24.4	11.9	27	26.0	28.5	38.9	12-8 SCM-Rs
3/4	3/4	52.8	15.7	21.8	24.4	15.8	35	32.0	28.5	42.7	12 SCM-Rs
3/4	1	55.4	18.3	21.8	24.4	15.8	41	39.0	28.5	45.6	12-16 SCM-Rs
1	1/2	55.9	14.2	26.4	31.2	11.9	35	26.0	38	43.7	16-8 SCM-Rs
1	3/4	57.5	15.7	26.4	31.2	15.8	35	32.0	38	45.2	16-12 SCM-Rs
1	1	60.0	18.3	26.4	31.2	19.8	41	39.0	38	47.8	16 SCM-Rs
1.1/4	1.1/4	78.9	19.8	38.9	41.2	25.0	50	49.0	50	55.9	20 SCM-Rs
1.1/2	1.1/2	90.8	22.1	45.2	50.0	31.8	60	54.7	57	63.2	24 SCM-Rs

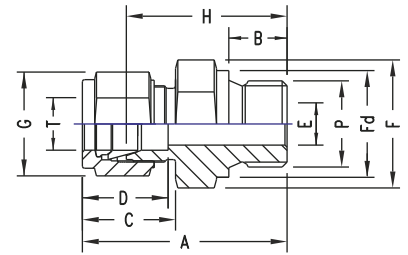

METRIC OD Tube x Male ISO* Parallel Threads - RS

T Tube OD	P ISO Male	A	B	C	D	E min.	F A/F	Fd	G A/F	H	Fluid Controls Part No.
3	1/8	30.0	7.1	15.3	12.9	2.4	14	13.8	11	23.4	SCM 3-2 Rs
3	1/4	35.3	11.2	15.3	12.9	2.4	19	18.0	11	28.7	SCM 3-4 Rs
6	1/8	32.3	7.1	17.7	15.3	4.8	14	13.8	14	24.9	SCM 6-2 Rs
6	1/4	37.6	11.2	17.7	15.3	4.8	19	18.0	14	30.2	SCM 6-4 Rs
6	3/8	38.9	11.2	17.7	15.3	4.8	22	21.8	14	31.5	SCM 6- Rs
6	1/2	44.7	14.2	17.7	15.3	4.8	27	26.0	14	37.3	SCM 6-8 Rs
8	1/8	33.2	7.1	18.6	16.2	4.0	14	13.8	16	25.7	SCM 8-2 Rs
8	1/4	38.5	11.2	18.6	16.2	6.4	19	18.0	16	31.0	SCM 8-4 Rs
8	3/8	39.8	11.2	18.6	16.2	6.4	22	21.8	16	32.3	SCM 8-6 Rs
8	1/2	45.6	14.2	18.6	16.2	6.4	27	26.0	16	38.1	SCM 8 Rs
10	1/4	39.4	11.2	19.5	17.2	5.9	19	18.0	19	31.8	SCM 10-4 Rs
10	3/8	40.6	11.2	19.5	17.2	7.6	22	21.8	19	33.0	SCM 10-6 Rs
10	1/2	46.5	14.2	19.5	17.2	7.9	27	26.0	19	38.9	SCM 10-8 Rs
12	1/4	42.6	11.2	22.0	22.8	5.9	22	18.0	22	32.5	SCM 12-4 Rs
12	3/8	43.1	11.2	22.0	22.8	7.9	22	21.8	22	33.0	SCM 12-6 Rs
12	1/2	49.0	14.2	22.0	22.8	9.5	27	26.0	22	38.9	SCM 12-8 Rs
12	3/4	52.8	15.7	22.0	22.8	9.5	35	32.0	22	42.7	SCM 12 Rs
16	3/8	43.9	11.2	22.0	24.4	7.9	24	21.8	25	33.8	SCM 16-6 Rs
16	1/2	49.0	14.2	22.0	24.4	11.9	27	26.0	25	38.9	SCM 16-8 Rs
20	1/2	50.5	14.2	22.0	26.0	11.9	30	26.0	28.5	40.4	SCM 20-8 Rs
20	3/4	52.3	15.7	22.0	26.0	15.9	35	32.0	28.5	42.7	SCM 22-12 Rs
22	3/4	52.3	15.7	22.0	26.0	15.9	35	32.0	32	42.7	SCM 20-16 Rs
22	1	55.3	18.3	22.0	26.0	18.3	41	39.0	32	45.2	SCM 25-12 Rs
25	3/4	57.5	15.7	26.5	31.3	15.9	35	32.0	38	45.2	SCM 20-16 Rs
25	1	60.1	18.3	26.5	31.3	19.8	41	39.0	38	47.8	SCM 20-12 Rs
28	1	70.1	18.3	36.6	36.6	19.8	41	39.0	46	49.3	SCM 28-16 Rs
30	1.1/4	76.5	19.8	39.2	39.6	25.0	50	49.0	50	54.9	SCM 30-20 Rs
32	1.1/4	78.9	19.8	41.6	42.0	25.0	50	49.0	50	55.9	SCM 32-20 Rs
38	1.1/2	90.8	22.1	47.9	49.4	31.8	55	54.7	57	63.2	SCM 38-24 Rs

* Reference Specifications : BS 2779 : ISO 228/1 : JIS B0202 : DIN-ISO 228/1

NOTE: The ISO Parallel Thread system shown on this page does not create pressure tight seal against the threads. The seal is made by a bounded washer seal between the fitting and female part face. A soft metal (Copper) Gasket way also be used.

O SEAL MALE CONNECTOR

INCH OD Tubes x Male ISO* Parallel Threads

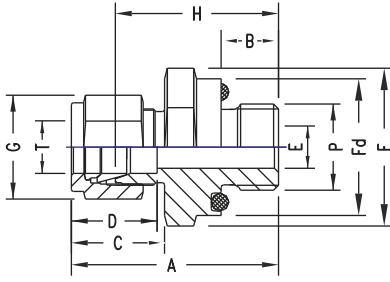

T Tube OD	P ISO Male	A	B	C	D	E min.	F A/F	Fd	G A/F	H	O Ring Part No.	Fluid Controls Part No.
1/8	1/8	32.8	7.1	15.3	12.7	2.4	19	18.8	11	26.2	2 OPN	2 SCO-R
1/4	1/8	35.0	7.1	17.8	15.3	4.8	19	18.8	14	27.7	2 OPN	4-2 SCO-R
1/4	1/4	40.0	11.2	17.8	15.3	7.1	24	23.6	14	32.6	4OPN	4 SCO-R
3/8	1/4	41.5	11.2	19.3	16.8	7.1	24	23.6	17	34.1	4 OPN	6-4 SCO-R
3/8	3/8	42.2	11.2	19.3	16.8	7.1	30	29.8	17	34.8	6 OPN	6 SCO-R
3/8	1/2	47.7	14.2	19.3	16.8	9.6	32	31.8	17	40.3	8 OPN	6-8 SCO-R
1/2	3/8	44.5	10.4	21.8	22.9	10.4	30	29.8	22	34.4	6 OPN	8-6 SCO-R
1/2	1/2	50.4	14.2	21.8	22.9	11.9	32	31.8	22	40.3	8 OPN	8 SCO-R
5/8	1/2	50.4	14.2	21.8	24.4	11.9	32	31.8	22	40.3	8 OPN	10-8 SCO-R
3/4	1/2	50.4	14.2	21.8	24.4	15.8	32	31.8	28.5	40.3	8 OPN	12-8 SCO-R
3/4	3/4	53.5	15.7	21.8	24.4	15.8	38	37.8	28.5	43.4	12 OPN	12 SCO-R
1	3/4	58.2	15.7	26.4	31.2	22.3	38	37.8	38	46.0	12OPN	16-12 SCO-R
1	1	62.2	18.3	26.4	31.2	27.6	45	44.0	38	50.0	16 OPN	16 SCO-R
1.1/4	1.1/4	77.6	12.0	38.9	41.4	27.6	55	54.0	50	55.6	20 OPN	20 SCO-R
1.1/2	1.1/2	88.9	12.0	45.2	50.0	34.0	60	58.0	57	61.7	24 OPN	24 SCO-R

METRIC OD Tubes x Male ISO* Parallel Threads

T Tube OD	P ISO Male	A	B	C	D	E min.	F A/F	Fd	G A/F	H	O Ring Part No.	Fluid Controls Part No.
3	1/8	32.8	7.1	15.3	12.9	2.4	19	18.8	11	26.2	2 OPN	SCO 3-2 R
3	1/4	37.6	11.2	15.3	12.9	2.4	24	23.8	11	31.0	4 OPN	SCO 3-4 R
6	1/4	40.1	11.2	17.7	15.3	4.8	24	23.8	14	32.7	4 OPN	SCO 6-4 R
6	3/8	40.8	11.2	17.7	15.3	4.8	30	29.8	14	33.4	6 OPN	SCO 6 R
8	1/4	40.9	11.2	18.6	16.2	6.3	24	23.8	16	33.4	4 OPN	SCO 8-4 R
10	1/4	41.0	11.2	19.5	17.2	7.1	24	23.8	17	33.4	4 OPN	SCO 10-4 R
10	3/8	42.6	11.2	19.5	17.2	7.1	30	29.8	17	35.0	6 OPN	SCO 10-6 R
10	1/2	48.0	14.2	19.5	17.2	7.9	32	31.8	17	40.4	8 OPN	SCO 10-8 R
12	1/4	44.3	11.2	22.0	22.8	7.1	24	21.8	22	34.2	4 OPN	SCO 12-4 R
12	3/8	45.1	11.2	22.0	22.8	7.9	30	29.8	22	34.0	6 OPN	SCO 12-6 R
12	1/2	50.5	14.3	22.0	22.8	9.5	32	31.8	22	40.4	8 OPN	SCO 12-8 R
16	1/2	50.5	14.3	22.0	24.4	11.9	32	31.8	25	40.4	8 OPN	SCO 16-8 R
20	3/4	55.1	15.7	22.0	26.0	15.8	38	37.0	32	45.0	12 OPN	SCO 20-2 R
25	3/4	58.1	15.7	26.5	31.3	15.8	38	37.0	38	45.8	12 OPN	SCO 25-2 R
25	1	62.3	18.3	26.5	31.3	19.8	45	44.0	38	50.0	16 OPN	SCO 25-16 R

* Reference Specifications : BS 2779 : ISO 228/1 : JIS B0202 : DIN-ISO 228/1

INCH OD Tube x Male Straight Threads - UNF

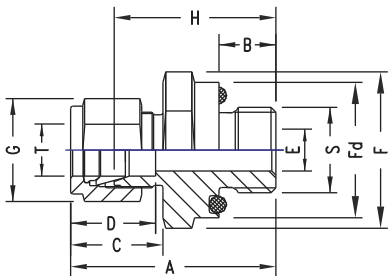

T Tube OD	S Thread Male	A	B	C	D	E min.	F A/F	Fd	G A/F	H	O Ring Part No.	Fluid Controls Part No.
1/8	5/16 -24	32.8	8.6	15.3	12.7	2.4	14	13.8	11	26.2	1 OPU	2 SCO-U
1/4	7/16 -20	38.4	10.4	17.8	15.3	4.8	19	18.8	14	31.0	2 OPU	4 SCO-U
5/16	1/2 -20	40.6	11.2	18.5	16.3	6.3	22	21.8	16	33.3	3 OPU	5 SCO-U
3/8	9/16 -18	42.4	12.0	19.3	16.8	7.1	24	23.6	17	35.0	4 OPU	6 SCO-U
1/2	3/4 -16	46.0	12.0	21.8	22.9	10.4	28.5	28.0	22	35.8	6 OPU	8 SCO-U
3/4	11/16 -12	52.4	14.3	21.8	24.4	15.8	38	37.8	28.5	42.2	12 OPU	12 SCO-U
1	15/16 -12	58.2	14.3	26.4	31.2	22.3	45	44.0	38	46.0	16 OPU	16 SCO-U
1.1/4	15/8 -12	76.2	18.3	38.9	41.4	27.6	55	54.0	50	54.1	20 OPU	20 SCO-U
1.1/2	17/8 -12	86.6	19.8	45.2	50.0	34.0	60	58.0	57	59.4	24 OPU	24 SCO-U

BULKHEAD MALE CONNECTOR

INCH OD Tubes x Male NPT Threads

T Tube OD	P NPT Male	A	Ax	B	D	E min.	F A/F	G A/F	H	Hx	Panel Hole Drill Size	Max. Panel Thick- ness	Fluid Controls Part No.
1/8	1/8	46.4	31.2	9.6	12.7	2.4	14	11	39.8	24.6	8.3	12.7	2 SCMB-N
1/4	1/8	49.5	33.5	9.6	15.3	4.8	16	14	42.2	26.2	11.5	10.2	4-2 SCMB-N
1/4	1/4	54.1	33.5	14.3	15.3	4.8	16	14	46.7	26.2	11.5	10.2	4 SCMB-N
3/8	1/4	57.4	36.8	14.3	16.8	7.1	19	17	50.0	29.5	14.7	11.2	6-4 SCMB-N
3/8	3/8	57.4	36.8	14.3	16.8	7.1	19	17	50.0	29.5	14.7	11.2	6 SCMB-N
3/8	1/2	63.7	36.8	19.1	16.8	7.1	22	17	56.5	29.5	14.7	11.2	6-8 SCMB-N
1/2	3/8	63.3	41.9	14.3	22.9	9.6	24	22	53.0	31.8	19.5	12.7	8-6 SCMB-N
1/2	1/2	68.8	41.9	19.1	22.9	10.4	24	22	58.8	31.8	19.5	12.7	8 SCMB-N
3/4	3/4	76.2	47.5	19.1	24.4	15.8	30	28.5	66.9	37.4	25.8	16.8	12 SCMB-N
1	1	93.2	57.4	23.9	31.2	22.3	41	38	81.0	45.2	33.7	19.0	16 SCMB-N
1.1/4	1.1/4	110.5	72.5	23.9	41.2	27.6	50	50	87.5	49.5	42.5	19.0	20 SCMB-N
1.1/2	1.1/2	122.8	79.1	26.2	50.0	34.0	60	57	95.5	51.5	50.5	19.0	24 SCMB-N

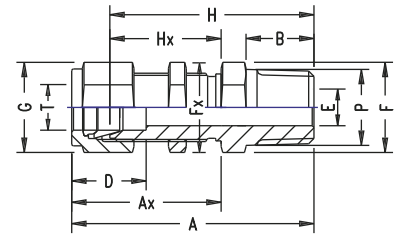

METRIC OD Tubes x Male NPT Threads

T Tube OD	P NPT Male	A	Ax	B	D	E min.	F A/F	G A/F	H	Hx	Panel Hole Drill Size	Max. Panel Thick- ness	Fluid Controls Part No.
3	1/8	46.4	31.2	9.6	12.9	2.4	11	11	39.8	24.6	8.3	12.7	SCMB 3-2N
6	1/8	49.5	33.5	9.6	15.3	4.8	16	14	42.2	26.2	11.5	10.2	SCMB 6-2N
10	1/4	57.4	36.8	14.3	17.2	7.1	19	17	50.0	29.5	14.7	11.2	SCMB 10-4N
10	3/8	57.4	36.8	14.3	17.2	7.1	19	17	50.0	29.5	14.7	11.2	SCMB 10-4N
12	3/8	63.3	41.9	14.3	22.0	9.6	24	22	53.0	31.8	19.5	12.7	SCMB 12-6N
12	1/2	68.8	41.9	19.1	22.0	10.4	24	22	58.8	31.8	19.5	12.7	SCMB 12-8N
16	1/2	69.6	42.6	19.1	24.4	11.9	27	25	59.5	32.5	22.8	12.7	SCMB 16-8N
22	3/4	83.3	53.0	19.1	26.0	15.8	35	25	73.2	42.9	29.0	19.0	SCMB 22-12N
25	1	93.2	57.4	23.9	31.3	22.3	41	38	81.0	45.2	33.7	19.0	SCMB 25-16N
32	1.1/4	110.5	72.5	23.9	42.0	28.6	50	50	87.5	49.5	42.5	19.0	SCMB 32-20N
38	1.1/2	122.8	79.1	26.2	49.4	33.7	60	57	95.5	51.5	50.5	19.0	SCMB 38-24N

NOTE: Bulkhead Male Connectors are also available with ISO Taper Male Threads, ISO Parallel Male Threads, ISO Parallel Male Threads - RP and RS and UNEF Threads. Please consult us for details.

MALE ELBOW

INCH OD Tubes x Male NPT Thread

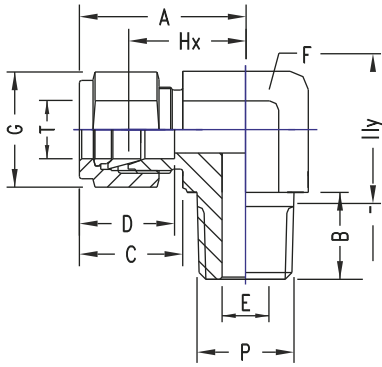

T Tube OD	P NPT Male	A	B	C	D	E min.	F A/F	G A/F	Hx	Hy	Fluid Controls Part No.
1/16	1/16	19.0	9.6	10.9	8.6	1.3	11	11	15.3	17.8	1 SEM-N
1/16	1/8	19.0	9.6	10.9	8.6	1.3	11	11	15.3	17.8	1-2 SEM-N
1/8	1/8	23.6	9.6	15.3	12.7	2.4	11	11	17.0	17.8	2 SEM-N
1/8	1/4	24.6	14.3	15.3	12.7	2.4	14	11	18.0	23.4	2-4 SEM-N
1/4	1/8	26.9	9.6	17.8	5.3	4.8	14	14	19.6	18.8	4-2 SEM-N
1/4	1/4	26.9	14.3	17.8	15.3	4.8	14	14	19.6	23.4	4 SEM-N
1/4	3/8	29.7	14.3	17.8	15.3	4.8	19	14	22.4	26.2	4-6 SEM-N
1/4	1/2	31.8	19.1	17.8	15.3	4.8	22	14	24.4	33.0	4-8 SEM-N
5/16	1/4	28.7	9.6	18.5	16.3	6.3	14	16	21.3	24.4	5-4 SEM-N
3/8	1/8	30.5	9.6	19.3	16.8	4.8	14	17	23.1	20.9	6-2 SEM-N
3/8	1/4	30.5	14.3	19.3	16.8	7.1	17	17	23.1	25.4	6-4 SEM-N
3/8	3/8	31.2	14.3	19.3	16.8	7.1	19	17	23.9	26.2	6 SEM-N
3/8	1/2	33.3	19.1	19.3	16.8	7.1	22	17	25.9	33.0	6-8 SEM-N
1/2	1/4	36.0	14.3	21.8	22.9	4.8	22	22	25.9	28.2	8-4 SEM-N
1/2	3/8	36.0	14.3	21.8	22.9	9.6	22	22	25.9	28.2	8-6 SEM-N
1/2	1/2	36.0	19.1	21.8	22.9	10.4	22	22	25.9	33.0	8 SEM-N
1/2	3/4	39.9	19.1	21.8	22.9	10.4	27	22	29.7	36.8	8-12 SEM-N
5/8	1/2	38.1	19.1	21.8	24.4	11.9	24	25	27.9	35.0	10-8 SEM-N
3/4	1/2	39.9	19.1	21.8	24.4	11.9	27	28.5	29.7	36.8	12-8 SEM-N
3/4	3/4	39.9	19.1	21.8	24.4	15.8	27	28.5	29.7	36.8	12 SEM-N
7/8	3/4	44.7	19.1	21.8	25.9	15.8	35	32	34.5	41.6	14-12 SEM-N
1	3/4	49.0	19.1	26.4	31.2	15.8	35	38	36.8	41.6	16-12 SEM-N
1	1	49.0	23.8	26.4	31.2	22.3	35	38	36.8	46.5	16 SEM-N
1.1/4	1.1/4	66.5	23.8	38.8	41.1	27.6	46	50	44.5	47.8	20 SEM-N
1.1/2	1.1/2	78.0	26.2	45.2	50.0	34.0	55	57	50.8	60.4	24 SEM-N
2	2	107.2	26.9	62.7	67.6	46.0	70	76	69.9	70.6	32 SEM-N

INCH OD Tubes x Male ISO* Tapered Pipe Threads

T Tube OD	P ISO Male	A	B	C	D	E min.	F A/F	G A/F	Hx	Hy	Fluid Controls Part No.
1/8	1/8	23.6	9.6	15.3	12.7	2.4	11	11	17.0	17.8	2 SEM-Rx
1/8	1/4	24.6	14.3	15.3	12.7	2.4	14	11	18.0	23.4	2-4 SEM-Rx
1/4	1/8	26.9	9.6	17.8	5.3	4.8	14	14	19.6	18.8	4-2 SEM-Rx
1/4	1/4	26.9	14.3	17.8	15.3	4.8	14	14	19.6	23.4	4 SEM-Rx
1/4	3/8	29.7	14.3	17.8	15.3	4.8	19	14	22.4	26.2	4-6 SEM-Rx
1/4	1/2	31.8	19.1	17.8	15.3	4.8	22	14	24.4	33.0	4-8 SEM-Rx
3/8	1/8	30.5	9.6	19.3	16.8	4.8	14	17	23.1	20.9	6-2 SEM-Rx
3/8	1/4	30.5	14.3	19.3	16.8	7.1	17	17	23.1	25.4	6-4 SEM-Rx
3/8	3/8	31.2	14.3	19.3	16.8	7.1	19	17	23.9	26.2	6 SEM-Rx
3/8	1/2	33.3	19.1	19.3	16.8	7.1	22	17	25.9	33.0	6-8 SEM-Rx
1/2	1/4	36.0	14.3	21.8	22.9	4.8	22	22	25.9	28.2	8-4 SEM-Rx
1/2	3/8	36.0	14.3	21.8	22.9	9.6	22	22	25.9	28.2	8-6 SEM-Rx
1/2	1/2	36.0	19.1	21.8	22.9	10.4	22	22	25.9	33.0	8 SEM-Rx
1/2	3/4	39.9	19.1	21.8	22.9	10.4	27	22	29.7	36.8	8-12 SEM-Rx
3/4	1/2	39.9	19.1	21.8	24.4	11.9	27	28.5	29.7	36.8	12-8 SEM-Rx
3/4	3/4	39.9	19.1	21.8	24.4	15.8	27	28.5	29.7	36.8	12 SEM-Rx
1	3/4	49.0	19.1	26.4	31.2	15.8	35	38	36.8	41.6	16-12 SEM-Rx
1	1	49.0	23.8	26.4	31.2	22.3	35	38	36.8	46.5	16 SEM-Rx
1.1/4	1.1/4	66.5	23.8	38.8	41.1	27.6	46	50	44.5	47.8	20 SEM-Rx
1.1/2	1.1/2	78.0	26.2	45.2	50.0	34.0	55	57	50.8	60.4	24 SEM-Rx

* Reference Specifications : BS 21: ISO 7/1 : JIS B 0203 : DIN 2999 : IS 554

NOTE: The combination of tube OD and male threads are indicative of popular sizes. Other combinations, not shown, are available. Please Consult us.

MALE ELBOW

METRIC OD Tubes x Male NPT Threads



T Tube OD	P NPT Male	A	B	C	D	E min.	F A/F	G A/F	Hx	Hy	Fluid Controls Part No.
3	1/8	23.6	9.6	15.3	12.9	2.4	11	11	17.0	17.8	SEM-3-2N
3	1/4	24.6	14.3	15.3	12.9	2.4	14	11	18.0	23.4	SEM-3-4N
6	1/8	27.0	9.6	17.7	15.3	4.8	14	14	19.6	18.8	SEM-6-2N
6	1/4	27.0	14.3	17.7	15.3	4.8	14	14	19.6	23.4	SEM-6-4N
6	3/8	29.8	14.3	17.7	15.3	4.8	19	14	22.4	26.2	SEM-6N
6	1/2	31.8	19.1	17.7	15.3	4.8	22	14	24.4	33.0	SEM-6-8N
8	1/8	28.8	9.6	18.6	16.2	4.8	14	16	21.3	19.8	SEM-8-2N
8	1/4	28.8	14.3	18.6	16.2	6.3	14	16	21.3	24.4	SEM-8-4N
8	3/8	30.6	14.3	18.6	16.2	6.3	19	16	23.1	26.2	SEM-8-6N
8	1/2	32.6	19.1	18.6	16.2	6.3	22	16	25.1	33.0	SEM-8N
10	1/8	31.5	9.6	19.5	17.2	4.8	17	19	23.9	21.6	SEM-10-2N
10	1/4	31.5	14.3	19.5	17.2	7.1	17	19	23.9	26.2	SEM-10-4N
10	3/8	31.5	14.3	19.5	17.2	7.9	19	19	23.9	26.2	SEM-10-6N
10	1/2	33	19.1	19.5	17.2	7.9	22	19	25.9	33.0	SEM-10-8N
12	1/4	36.0	14.3	22.0	22.8	7.1	22	22	25.9	26.2	SEM-12-4N
12	3/8	36.0	14.3	22.0	22.8	9.5	22	22	25.9	38.2	SEM-12-6N
12	1/2	36.0	19.1	22.0	22.8	9.5	22	22	25.9	33.0	SEM-12-8N
12	3/4	39.8	19.1	22.0	22.8	9.5	27	22	29.7	36.8	SEM-12N
15	1/2	38.0	19.1	22.0	24.4	11.9	24	25	27.9	35.1	SEM-15-8N
16	1/2	38.0	19.1	22.0	24.4	11.9	24	25	27.9	35.1	SEM-16-8N
16	3/4	39.8	19.1	22.0	24.4	27.7	27	25	29.7	36.8	SEM-16-12N
18	1/2	39.8	19.1	22.0	24.4	11.9	27	30	29.7	36.8	SEM-18-8N
18	3/4	39.8	19.1	22.0	24.4	15.1	27	30	29.7	36.8	SEM-18-12N
20	1/2	44.6	19.1	22.0	26.0	11.9	35	32	34.5	41.7	SEM-20-8N
20	3/4	44.6	19.1	22.0	26.0	15.9	35	32	34.5	41.7	SEM-20-12N
22	3/4	44.6	19.1	22.0	26.0	15.9	35	32	34.5	41.7	SEM-22-12N
22	1	44.6	23.9	22.0	26.0	18.3	35	32	34.5	46.5	SEM-22-16N
25	3/4	49.1	19.1	26.5	31.3	59.9	35	38	36.8	41.7	SEM-25-12N
25	1	41.1	23.9	26.5	31.3	21.8	35	38	36.8	46.5	SEM-25-16N
30	1.1/4	69.9	23.9	39.2	39.6	26.2	45	50	48.3	53.1	SEM-30-20N
32	1.1/4	72.3	23.9	41.6	42.0	27.6	45	50	49.3	53.1	SEM-32-20N
38	1.1/2	84.0	26.2	47.9	49.4	33.7	55	57	56.4	60.4	SEM-38-24N

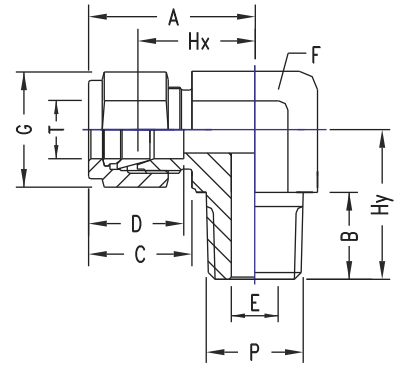

METRIC OD Tubes x Male ISO* Tapered Pipe Threads

T Tube OD	P ISO Male	A	B	C	D	E min.	F A/F	G A/F	Hx	Hy	Fluid Controls Part No.
3	1/8	23.6	9.6	15.3	12.9	2.4	11	11	17.0	17.8	SEM-3-2Rx
3	1/4	24.6	14.3	15.3	12.9	2.4	14	11	18.0	23.4	SEM-3-4Rx
6	1/8	27.0	9.6	17.7	15.3	4.8	14	14	19.6	18.8	SEM-6-2Rx
6	1/4	27.0	14.3	17.7	15.3	4.8	14	14	19.6	23.4	SEM-6-4Rx
6	3/8	29.8	14.3	17.7	15.3	4.8	19	14	22.4	26.2	SEM-6Rx
6	1/2	31.8	19.1	17.7	15.3	4.8	22	14	24.4	33.0	SEM-6-8Rx
8	1/4	28.8	14.3	18.6	16.2	6.3	14	16	21.3	24.4	SEM-8-4Rx
8	3/8	30.6	14.3	18.6	16.2	6.3	19	16	23.1	26.2	SEM-8-6Rx
8	1/2	32.6	19.1	18.6	16.2	6.3	22	16	25.1	33.0	SEM-8Rx
10	1/4	31.5	14.3	19.5	17.2	7.1	17	19	23.9	26.2	SEM-10-4Rx
10	3/8	31.5	14.3	19.5	17.2	7.9	19	19	23.9	26.2	SEM-10-6Rx
10	1/2	33	19.1	19.5	17.2	7.9	22	19	25.9	33.0	SEM-10-8Rx
12	1/4	36.0	14.3	22.0	22.8	7.1	22	22	25.9	26.2	SEM-12-4Rx
12	3/8	36.0	14.3	22.0	22.8	9.5	22	22	25.9	38.2	SEM-12-6Rx
12	1/2	36.0	19.1	22.0	22.8	9.5	22	22	25.9	33.0	SEM-12-8Rx
15	1/2	38.0	19.1	22.0	24.4	11.9	24	25	27.9	35.1	SEM-15-8Rx
16	1/2	38.0	19.1	22.0	24.4	11.9	24	25	27.9	35.1	SEM-16-8Rx
16	3/4	39.8	19.1	22.0	24.4	27.7	27	25	29.7	36.8	SEM-16-12Rx
22	3/4	44.6	19.1	22.0	26.0	15.9	35	32	34.5	41.7	SEM-22-12Rx
22	1	44.6	23.9	22.0	26.0	18.3	35	32	34.5	46.5	SEM-22-16Rx
25	3/4	49.1	19.1	26.5	31.3	59.9	35	38	36.8	41.7	SEM-25-12Rx
25	1	41.1	23.9	26.5	31.3	21.8	35	38	36.8	46.5	SEM-25-16Rx
30	1.1/4	69.9	23.9	39.2	39.6	26.2	45	50	48.3	53.1	SEM-30-20Rx
32	1.1/4	72.3	23.9	41.6	42.0	27.6	45	50	49.3	53.1	SEM-32-20Rx
38	1.1/2	84.0	26.2	47.9	49.4	33.7	55	57	56.4	60.4	SEM-38-24Rx

* Reference Specifications : BS 21: ISO 7/1 : JIS B 0203 : DIN 2999 : IS 554

45 DEG. MALE ELBOW

INCH OD Tubes x Male NPT Threads

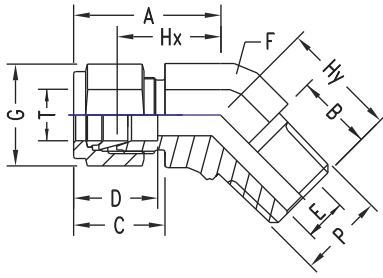

T Tube OD	P NPT Male	A	B	C	D	E min.	F A/F	G A/F	Hx	Hy	Fluid Controls Part No.
1/4	1/8	24.6	9.6	17.8	15.3	4.8	14	14	17.3	16.5	4-2 SEM/45-N
1/4	1/4	24.6	14.3	17.8	15.3	4.8	14	14	17.3	21.0	4 SEM/45-N
3/8	1/8	27.9	9.6	19.3	16.8	4.8	14	17	20.6	18.3	6-2 SEM/45-N
3/8	1/4	27.9	14.3	19.3	16.8	7.1	17	17	20.6	22.9	6-4 SEM/45-N
3/8	3/8	29.2	14.3	19.3	16.8	7.1	19	17	21.8	24.1	6 SEM/45-N
1/2	3/8	32.0	14.3	21.8	22.9	9.6	22	22	21.8	24.1	8-6 SEM/45-N
1/2	1/2	32.0	19.1	21.8	22.9	10.4	22	22	21.8	29.0	8 SEM/45-N
3/4	3/4	34.0	19.1	21.8	24.4	15.8	27	28.5	23.9	31.8	12 SEM/45-N
1	1	40.4	23.8	26.4	31.2	22.3	35	38	26.2	37.8	16 SEM/45-N

45 DEG. POSITIONABLE MALE ELBOW

INCH OD Tube x SAE/MS Straight Threads

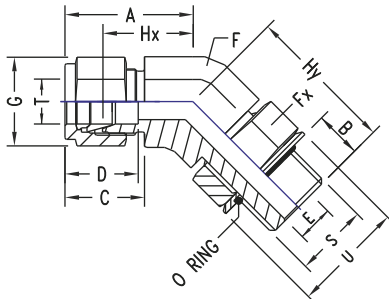

T Tube OD	P SAE/MS Male	A	B	C	D	E min.	F	Fx A/F	G A/F	Hx A/F	Hy	U	O Ring Part No.	Fluid Controls Part No.
1/4	7/16-20	25.7	9.9	17.8	15.3	4.8	14	14	14	18.3	25.6	16.5	4 OPU	4 SEsw/45-U
3/8	9/16-18	27.9	11.2	19.3	16.8	7.1	16	17	17	20.6	28.2	20.0	6 OPU	6 SEsw/45-U
1/2	3/4-16	32.0	12.7	21.8	22.9	10.4	22	22	22	21.8	32.3	25.7	8 OPU	8 SEsw/45-U
3/4	1 1/16-12	39.9	16.8	21.8	24.4	15.8	27	32	28.5	29.7	47.3	36.6	12 OPU	12 SEsw/45-U
1	1 5/16-12	47.5	16.8	26.4	31.2	19.8	35	38	38	35.3	50.6	44.0	16 OPU	16 SEsw/45-U

* Reference Specifications : SAE Screw Thread standard conforms to American standard B1.1. Unified screw threads.

INCH OD Tube x Male ISO* Parallel Threads

T Tube OD	P ISO Male	A	B	C	D	E min.	F	Fx A/F	G A/F	Hx A/F	Hy	U	O Ring Part No.	Fluid Controls Part No.
1/4	1/4	25.7	9.9	17.8	15.3	4.8	14	14	14	18.3	25.6	16.5	4 OPU	4 SEsw/45-R
3/8	3/8	27.9	11.2	19.3	16.8	7.1	16	17	17	20.6	28.2	20.0	6 OPU	6 SEsw/45-R
1/2	1/2	32.0	12.7	21.8	22.9	10.4	22	22	22	21.8	32.3	25.7	8 OPU	8 SEsw/45-R
3/4	3/4	39.9	16.8	21.8	24.4	15.8	27	32	28.5	29.7	47.3	36.6	12 OPU	12 SEsw/45-R
1	1	47.5	16.8	26.4	31.2	19.8	35	38	38	35.3	50.6	44.0	16 OPU	16 SEsw/45-R

* Reference Specifications : BS 2779 : ISO 228/1 : JIS B0202 : DIN-ISO 228/1

POSITIONABLE MALE ELBOW

INCH OD Tubes X Male ISO* Parallel Threads



T Tube OD	P ISO Male	Ax	B	C	D	E min.	F	Fx A/F	G A/F	Hx A/F	Hy	U	O Ring Part No.	Fluid Controls Part No.
1/4	1/8	27.0	8.2	17.8	15.3	4.0	14	14	14	19.6	26.4	17.3	2 Opn	4-2 SEsw-R
1/4	1/4	29.0	9.2	17.8	15.3	4.8	16	19	14	21.6	32.3	22.9	4 Opn	4 SEsw-R
3/8	1/4	30.5	9.2	19.3	16.8	5.8	16	19	17	23.2	32.3	22.9	4 Opn	6-4 SEsw-R
3/8	3/8	33.0	9.2	19.3	16.8	7.1	22	22	17	25.9	37.0	26.4	6 Opn	6 SEsw-R
1/2	1/4	36.0	9.2	21.8	22.9	5.8	22	19	22	25.9	35.0	22.9	4 Opn	8-4 SEsw-R
1/2	3/8	36.0	9.4	21.8	22.9	7.8	22	22	22	25.9	37.0	26.4	6 Opn	8-6 SEsw-R
1/2	1/2	38.1	13.0	21.8	24.4	10.4	24	27	22	27.9	43.4	32.0	8 Opn	8 SEsw-R
5/8	1/2	38.1	13.0	21.8	24.4	10.4	24	27	25	27.9	43.4	32.0	8 Opn	10-8 SEsw-R
3/4	1/2	39.9	13.0	21.8	24.4	10.4	27	27	28.5	29.7	45.2	32.0	8 Opn	12-8 SEsw-R
3/4	3/4	39.9	13.0	21.8	24.4	15.8	27	35	28.5	29.7	48.8	41.2	12 Opn	12 SEsw-R
1	3/4	49.0	13.0	26.4	31.2	15.8	35	35	38	36.8	53.3	41.2	12 Opn	16-12 SEsw-R
1	1	49.0	14.0	26.4	31.2	19.8	35	41	38	36.8	53.6	48.5	16 Opn	16 SEsw-R

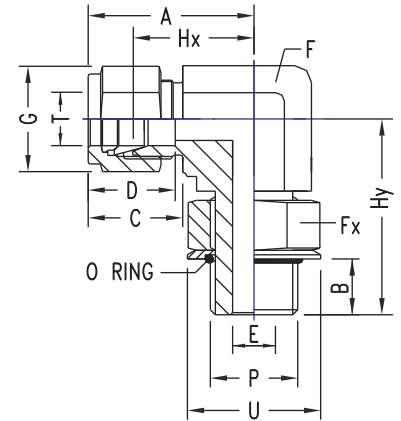

METRIC OD Tubes X Male ISO* Parallel Threads

T Tube OD	P ISO Male	Ax	B	C	D	E min.	F	Fx A/F	G A/F	Hx A/F	Hy	U	O Ring Part No.	Fluid Controls Part No.
6	1/8	27.0	8.1	17.7	15.3	4.0	14	14	14	19.6	26.4	17.3	2 Opn	SEsw 6-2R
6	1/4	29.0	9.1	17.7	15.3	4.8	16	19	14	21.6	32.3	22.9	4 Opn	SEsw 6-4R
8	1/8	28.8	8.1	18.6	16.2	4.0	14	14	16	21.3	27.4	17.3	2 Opn	SEsw 8-2R
8	1/4	29.9	9.1	18.6	16.2	5.9	16	19	16	22.4	32.2	22.9	4 Opn	SEsw 8-4R
10	1/4	33.5	9.1	19.5	17.2	5.9	19	19	19	25.9	35.0	22.9	4 Opn	SEsw 10-4R
10	3/8	33.5	9.4	19.5	17.2	7.9	19	22	19	25.9	37.1	26.4	6 Opn	SEsw 10-6R
12	3/8	36.0	9.4	22.0	22.8	7.9	22	22	22	25.9	37.1	26.4	6 Opn	SEsw 12-6R
12	1/2	38.0	13.0	22.0	22.8	9.5	24	27	22	27.9	43.4	32.0	8 Opn	SEsw 12-8R
12	3/4	39.8	13.0	22.0	22.8	9.5	27	35	22	29.7	48.8	41.1	12 Opn	SEsw 12R
16	1/2	38.1	13.0	22.0	24.4	11.9	27	27	28.5	29.7	45.2	32.0	8 Opn	SEsw 16-8R
22	3/4	44.6	13.0	22.0	26.0	15.8	27	35	28.5	34.5	48.8	41.2	12 Opn	SEsw 22-12R
25	3/4	49.0	13.0	26.5	31.3	15.8	35	35	38	36.8	53.3	41.2	12 Opn	SEsw 25-12R
25	1	49.0	14.0	26.5	31.3	21.8	35	41	38	36.8	53.6	48.5	16 Opn	Sesw 25-16R



* Reference Specifications : BS 2779 : ISO 228/1 : JIS B0202 : DIN-ISO 228/1

INCH OD Tube x SAE/MS Straight Threads

T Tube OD	P ISO Male	Ax	B	C	D	E min.	F	Fx A/F	G A/F	Hx	Hy	U	O Ring Part No.	Fluid Controls Part No.
1/4	7/16-20	28.5	9.9	17.8	15.3	4.8	14	14	14	21.0	28.5	16.5	4 OPU	4 SEsw-U
1/4	9/16-18	30.5	11.2	17.8	15.3	4.8	16	17	14	23.1	32.3	20.0	6 OPU	4-6 SEsw-U
3/8	9/16-18	32.0	11.2	19.3	16.8	7.1	16	17	17	24.6	32.3	20.0	6 OPU	6 SEsw-U
3/8	3/4-16	34.8	12.7	19.3	16.8	7.1	22	22	17	27.4	37.8	25.6	8 OPU	6-8 SEsw-U
1/2	3/4-16	37.6	12.7	21.8	22.9	10.4	22	22	22	27.4	37.8	25.6	8 OPU	8 SEsw-U
5/8	7/16-14	39.6	14.3	21.8	24.4	12.7	24	25	25	29.5	43.4	29.5	10 OPU	10 SEsw-U
3/4	11/16-12	41.4	16.8	21.8	24.4	15.8	27	32	28.5	31.2	48.8	36.6	12 OPU	12 SEsw-U
7/8	11/16-12	43.2	16.8	21.8	25.9	18.3	30	32	32	33	50.5	40.4	14 OPU	14 SEsw-U
1	15/16-12	50.5	16.8	26.4	31.2	22.3	35	35	38	38.4	53.6	44.0	16 OPU	16 SEsw-U
1.1/4	15/8-12	67.8	16.8	38.9	41.2	27.6	46	50	50	45.7	58.2	54.9	20 OPU	20 SEsw-U
1.1/2	17/8-12	78.0	16.8	45.2	50.0	34.0	50	55	60	50.8	60.4	62.5	24 OPU	24 SEsw-U

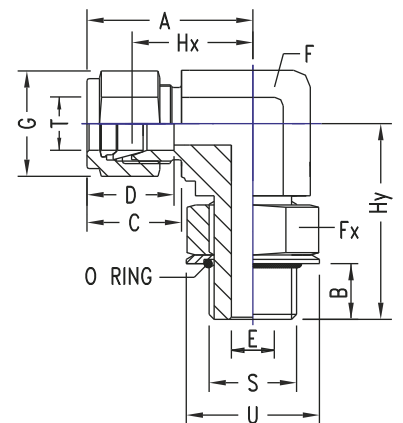

* Reference Specifications : SAE Screw Thread standard conforms to American standard B1.1. Unified screw threads.

MALE RUN TEE

INCH OD Tubes X Male NPT Threads

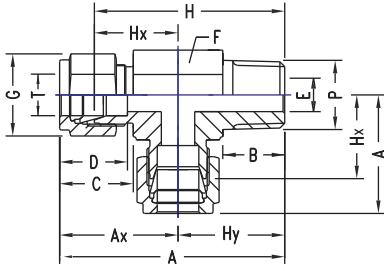

T Tube OD	P NPT Male	A	Ax	B	C	D	E min.	F	G A/F	H A/F	Hx	Hy	Fluid Controls Part No.
1/8	1/8	41.4	23.6	9.6	15.3	12.7	2.4	11	11	34.8	17.0	17.8	2 STRM-N
1/8	1/4	48.0	24.6	14.3	15.3	12.7	2.4	14	11	41.4	18.0	23.4	2-4 STRM-N
1/4	1/8	45.7	26.9	9.6	17.8	15.3	4.8	14	14	38.4	19.6	18.8	4-2 STRM-N
1/4	1/4	50.3	26.9	14.3	17.8	15.3	4.8	14	14	43	19.6	23.4	4 STRM-N
1/4	3/8	55.9	29.7	14.3	17.8	15.3	4.8	19	14	48.8	22.4	26.2	4-6 STRM-N
1/4	1/2	64.8	31.8	19.1	17.8	15.3	4.8	22	14	57.4	24.4	33.0	4-8 STRM-N
3/8	1/4	55.9	30.5	14.3	19.3	16.8	7.1	17	17	48.5	23.1	25.4	6-4 STRM-N
3/8	3/8	57.4	31.2	14.3	19.3	16.8	7.1	19	17	50.1	23.9	26.2	6 STRM-N
3/8	1/2	66.0	33.0	19.1	19.3	16.8	7.1	22	17	58.9	25.9	33.0	6-8 STRM-N
1/2	1/4	64.2	36.0	14.3	21.8	22.9	4.8	22	22	54.1	25.9	28.2	8-4 STRM-N
1/2	3/8	64.2	36.0	14.3	21.8	22.9	9.6	22	22	54.1	25.9	28.2	8-6 STRM-N
1/2	1/2	69.0	36.0	19.1	21.8	22.9	10.4	22	22	58.9	25.9	33.0	8 STRM-N
5/8	1/2	73.1	38.1	19.1	21.8	24.4	11.9	22	25	62.9	27.9	35.0	10-8 STRM-N
3/4	1/2	76.7	39.9	19.1	21.8	24.4	11.9	27	29	66.5	29.7	36.8	12-8 STRM-N
3/4	3/4	76.7	39.9	19.1	21.8	24.4	15.8	27	29	66.5	29.7	36.8	12 STRM-N
1	3/4	90.6	49.0	19.1	26.4	31.2	15.8	35	38	78.4	36.8	41.6	16-12 STRM N
1	1	95.5	49.0	23.8	26.4	31.2	22.3	35	38	83.3	36.8	46.5	16 STRM-N
1.1/4	1.1/4	114.1	66.5	23.8	38.8	41.1	27.6	46	50	92.1	44.5	47.6	20 STRM-N
1.1/2	1.1/2	138.4	78.0	26.2	45.2	50.0	34.0	55	57	111.2	50.8	60.4	24 STRM-N

METRIC OD Tubes X Male NPT Threads

T Tube OD	P NPT Male	A	Ax	B	C	D	E min.	F	G A/F	H A/F	Hx	Hy	Fluid Controls Part No.
3	1/8	41.4	23.6	9.6	15.3	12.9	2.4	11	11	34.8	17.0	17.8	STRM 3-2N
3	1/4	48.0	24.6	14.3	15.3	12.9	2.4	14	11	41.4	18.0	23.4	STRM 3-4N
6	1/8	45.8	27.0	9.6	17.7	15.3	4.8	14	14	38.9	19.6	18.8	STRM 6-2N
6	1/4	50.4	27.0	14.3	17.7	15.3	4.8	14	14	43.0	19.6	23.4	STRM 6-4N
6	3/8	56.0	29.8	14.3	17.7	15.3	4.8	19	14	48.6	22.4	26.2	STRM 6-N
8	1/4	53.2	28.8	14.3	18.6	16.2	6.3	14	16	45.7	21.3	24.4	STRM 8-4N
8	3/8	56.8	30.6	14.3	18.6	16.2	6.3	19	16	49.3	23.1	26.2	STRM 8-6N
8	1/2	65.6	32.6	19.1	18.6	16.2	6.3	22	16	58.1	25.1	33.0	STRM 8-N
10	1/4	57.7	31.5	14.3	19.5	17.2	7.1	17	19	50.1	23.9	26.2	STRM 10-4N
10	3/8	57.7	31.5	14.3	19.5	17.2	7.9	19	19	50.1	23.9	26.2	STRM 10-6N
10	1/2	66.5	33.5	19.1	19.5	17.2	7.9	22	19	58.9	25.9	33.0	STRM 10-8N
12	1/4	62.2	36.0	14.3	22.0	22.8	7.1	22	22	52.1	25.9	26.2	STRM 12-4N
12	3/8	62.2	36.0	14.3	22.0	22.8	9.5	22	22	52.1	25.9	28.2	STRM 12-6N
12	1/2	69.0	36.0	19.1	22.0	22.8	9.5	22	22	58.9	25.9	33.0	STRM 12-8N
16	1/2	73.1	38.0	19.1	22.0	24	11.9	24	25	64.0	27.9	35.1	STRM 16-8N
25	3/4	90.8	49.1	19.1	26.5	31.3	15.8	35	38	78.5	36.8	41.7	STRM 25-12N
25	1	95.6	49.1	23.8	26.5	31.3	21.8	35	38	83.3	36.8	46.5	STRM 25-16N
30	1.1/4	120.0	66.9	23.8	39.2	39.6	26.2	45	50	101.4	48.3	53.1	STRM 30-20N
32	1.1/4	125.4	72.3	23.8	41.6	42.0	27.6	45	50	102.4	49.3	53.1	STRM 32-20N
38	1.1/2	144.4	84.0	26.2	47.9	50.0	33.7	55	57	116.8	56.4	60.4	STRM 38-24N

NOTE: The combination of tube OD and male threads are indicative of popular sizes. Other combinations, not shown, are available. Please Consult us.

MALE BRANCH TEE

INCH OD Tubes x Male NPT Threads

T Tube OD	P NPT Male	A	Ax	B	C	D	E min.	F	G A/F	H A/F	Hx	Hy	Fluid Controls Part No.
1/8	1/8	47.2	23.6	9.6	15.3	12.7	2.4	11	11	34.0	17.0	17.8	2 STBM-N
1/8	1/4	49.2	24.6	14.3	15.3	12.7	2.4	14	11	36.0	18.0	23.4	2-4 STBM-N
1/4	1/8	53.8	26.9	9.6	17.8	5.3	4.8	14	14	39.2	19.6	18.8	4-2 STBM-N
1/4	1/4	53.8	26.9	14.3	17.8	15.3	4.8	14	14	39.2	19.6	23.4	4 STBM-N
1/4	3/8	59.4	29.7	14.3	17.8	15.3	4.8	19	14	44.8	22.4	26.2	4-6 STBM-N
1/4	1/2	63.6	31.8	19.1	17.8	15.3	4.8	22	14	44.8	24.4	33.0	4-8 STBM-N
3/8	1/4	61.0	30.5	14.3	19.3	16.8	7.1	17	17	46.2	23.1	25.4	6-4 STBM-N
3/8	3/8	62.4	31.2	14.3	19.3	16.8	7.1	19	17	47.8	23.9	26.2	6 STBM-N
3/8	1/2	66.0	33.0	19.1	19.3	16.8	7.1	22	17	51.8	25.9	33.0	6-8 STBM-N
1/2	1/4	72.0	36.0	14.3	21.8	22.9	4.8	22	22	51.8	25.9	28.2	8-4 STBM-N
1/2	3/8	72.0	36.0	14.3	21.8	22.9	9.6	22	22	51.8	25.9	28.2	8-6 STBM-N
1/2	1/2	72.0	36.0	19.1	21.8	22.9	10.4	22	22	51.8	25.9	33.0	8 STBM-N
5/8	1/2	76.2	38.1	19.1	21.8	24.4	11.9	22	25	55.8	27.9	35.0	10-8 STBM-N
3/4	1/2	79.8	39.9	19.1	21.8	24.4	11.9	27	29	59.4	29.7	36.8	12-8 STBM-N
3/4	3/4	79.8	39.9	19.1	21.8	24.4	15.8	27	29	59.4	29.7	36.8	12 STBM-N
1	3/4	98.0	49.0	19.1	26.4	31	15.8	35	38	73.6	36.8	41.6	16-12 STBM-N
1	1	98.0	49.0	23.8	26.4	31	22.3	35	38	73.6	36.8	46.5	16 STBM-N
1.1/4	1.1/4	133.0	66.5	23.8	38.8	41.1	27.6	46	50	89.0	44.5	47.6	20 STBM-N
1.1/2	1.1/2	156.0	78.0	26.2	45.2	50.0	34.0	55	57	101.6	50.8	60.4	24 STBM-N

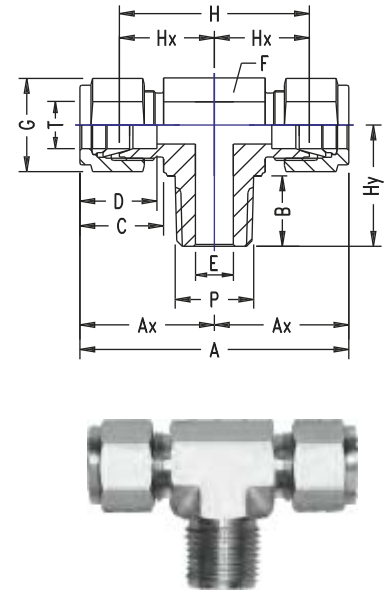

METRIC OD Tubes x Male NPT Threads

T Tube OD	P NPT Male	A	Ax	B	C	D	E min.	F	G A/F	H A/F	Hx	Hy	Fluid Controls Part No.
3	1/8	47.2	23.6	9.6	15.3	12.9	2.4	11	11	34.0	17.0	17.8	STBM 3-2N
3	1/4	49.2	24.6	14.3	15.3	12.9	2.4	14	11	36.0	18.0	23.4	STBM 3-4N
6	1/8	54.0	27.0	9.6	17.7	15.3	4.8	14	14	39.2	19.6	18.8	STBM 6-2N
6	1/4	54.0	27.0	14.3	17.7	15.3	4.8	14	14	39.2	19.6	23.4	STBM 6-4N
6	3/8	59.6	29.8	14.3	17.7	15.3	4.8	19	14	44.8	22.4	26.2	STBM 6-N
8	1/4	57.6	28.8	14.3	18.6	16.2	6.3	14	16	42.6	21.3	24.4	STBM 8-4N
8	3/8	61.2	30.6	14.3	18.6	16.2	6.3	19	16	46.2	23.1	26.2	STBM 8-6N
8	1/2	65.2	32.6	19.1	18.6	16.2	6.3	22	16	50.2	25.1	33.0	STBM 8-N
10	1/4	63.0	31.5	14.3	19.5	17.2	7.1	17	19	47.8	23.9	26.2	STBM 10-4N
10	3/8	63.0	31.5	14.3	19.5	17.2	7.9	19	19	47.8	23.9	26.2	STBM 10-6N
10	1/2	67.0	33.5	19.1	19.5	17.2	7.9	22	19	51.8	25.9	33.0	STBM 10-8N
12	1/4	72.0	36.0	14.3	22.0	22.8	7.1	22	22	51.8	25.9	26.2	STBM 12-4N
12	3/8	72.0	36.0	14.3	22.0	22.8	9.5	22	22	51.8	25.9	28.2	STBM 12-6N
12	1/2	72.0	36.0	19.1	22.0	22.8	9.5	22	22	51.8	25.9	33.0	STBM 12-8N
16	1/2	76.0	38.0	19.1	22.0	24	11.9	24	25	55.8	27.9	35.1	STBM 16-8N
25	3/4	98.2	49.1	19.1	26.5	31.3	15.8	35	38	73.6	36.8	41.7	STBM 25-12N
25	1	98.2	49.1	23.8	26.5	31.3	21.8	35	38	73.6	36.8	46.5	STBM 25-16N
30	1.1/4	139.8	66.9	23.8	39.2	39.6	26.2	45	50	96.6	48.3	53.1	STBM 30-20N
32	1.1/4	144.6	72.3	23.8	41.6	42.0	27.6	45	50	98.6	49.3	53.1	STBM 32-20N
38	1.1/2	168.0	84.0	26.2	47.9	50.0	33.7	55	57	112.8	56.4	60.4	STBM 38-24N

NOTE: The combination of tube OD and male threads are indicative of popular sizes. Other combinations, not shown, are available. Please Consult us.

POSITIONABLE MALE RUN TEE

INCH OD Tubes X Male ISO* Parallel Threads

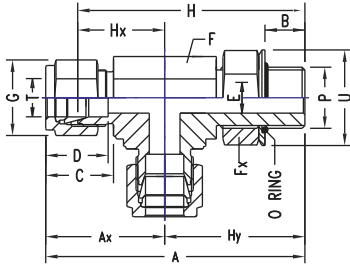

T Tube OD	P ISO Male	A	Ax	B	C	D	E min.	F A/F	Fx A/F	G A/F	H	Hx	Hy	U	O Ring Part No.	Fluid Controls Part No.
1/4	1/8	53.4	27.0	8.2	17.8	15.3	4.0	14	14	14	46.0	19.6	26.4	17.3	2 Opn	4-2 STRsw-R
1/4	1/4	61.3	29.0	9.2	17.8	15.3	4.8	16	19	14	53.9	21.6	32.3	22.9	4 Opn	4 STRsw-R
3/8	1/4	62.8	30.5	9.2	19.3	16.8	5.8	16	19	17	55.5	23.2	32.3	22.9	4 Opn	6-4 STRsw-R
1/2	3/8	73.0	36.0	9.4	21.8	22.9	7.8	22	22	22	62.9	25.9	37.0	26.4	6 Opn	8-6 STRsw-R
1/2	1/2	81.5	38.1	13.0	21.8	24.4	10.4	24	27	22	71.3	27.9	43.4	32.0	8 Opn	8 STRsw-R
5/8	1/2	81.5	38.1	13.0	21.8	24.4	10.4	24	27	25	71.3	27.9	43.4	32.0	8 Opn	10-8 STRsw-R
3/4	1/2	85.1	39.9	13.0	21.8	24.4	10.4	27	27	28.5	74.9	29.7	45.2	32.0	8 Opn	12-8 STRsw-R
3/4	3/4	88.7	39.9	13.0	21.8	24.4	15.8	27	35	28.5	78.5	29.7	48.8	41.2	12 Opn	12 STRsw-R
1	1	102.6	49.0	14.0	26.4	31.2	19.8	35	41	38	90.4	36.8	53.6	48.5	16 Opn	16 STRsw-R

METRIC OD Tubes X Male ISO* Parallel Threads



T Tube OD	P ISO Male	A	Ax	B	C	D	E min.	F A/F	Fx A/F	G A/F	H	Hx	Hy	U	O Ring Part No.	Fluid Controls Part No.
6	1/8	53.4	27.0	8.1	17.7	15.3	4.0	14	14	14	46.0	19.6	26.4	17.3	2 Opn	STR sw 6-2R
6	1/4	61.3	29.0	9.1	17.7	15.3	4.8	16	19	14	53.9	21.6	32.3	22.9	4 Opn	STR sw 6-4R
8	1/8	56.2	28.8	8.1	18.6	16.2	4.0	14	14	16	48.7	21.3	27.4	17.3	2 Opn	STR sw 8-2R
8	1/4	62.1	29.9	9.1	18.6	16.2	5.9	16	19	16	54.6	22.4	32.2	22.9	4 Opn	STR sw 8-4R
10	1/4	68.5	33.5	9.1	19.5	17.2	5.9	19	19	19	61.9	25.9	35.0	22.9	4 Opn	STR sw 10-4R
12	3/8	73.1	36.0	9.4	22.0	22.8	7.9	22	22	22	63.0	25.9	37.1	26.4	6 Opn	STR sw 12-6R
12	1/2	81.4	38.0	13.0	22.0	23	9.5	24	27	22	71.3	27.9	43.4	32.0	8 Opn	STR sw 12-8R
16	1/2	83.3	38.1	13.0	22.0	24.4	11.9	27	27	28.5	74.9	29.7	45.2	32.0	8 Opn	STR sw 16-8R
22	3/4	93.4	44.6	13.0	22.0	26.0	15.8	27	35	28.5	83.3	34.5	48.8	41.2	12 Opn	STR sw 22-12R
25	3/4	102.3	49.0	13.0	26.5	31.3	15.8	35	35	38	90.1	36.8	53.3	41.2	12 Opn	STR sw 25-12R
25	1	102.6	49.0	14.0	26.5	31.3	21.8	35	41	38	90.4	36.8	53.6	48.5	16 Opn	STR sw 25-16R

* Reference Specifications : BS 2779 : ISO 228/1 : JIS B0202 : DIN-ISO 228/1

POSITIONABLE BRANCH TEE

Inch OD Tubes X Male ISO* Parallel Thread

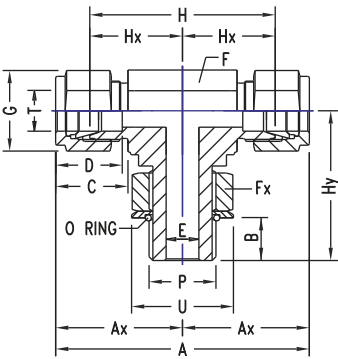

T Tube OD	P ISO Male	A	Ax	B	C	D	E min.	F A/F	Fx A/F	G A/F	H	Hx	Hy	U	O Ring Part No.	Fluid Controls Part No.
1/4	1/8	53.4	27.0	8.2	17.8	15.3	4.0	14	14	14	46.0	19.6	26.4	17.3	2 OPN	4-2 STBsw-R
1/4	1/4	61.3	29.0	9.2	17.8	15.3	4.8	16	19	14	53.9	21.6	32.3	22.9	4 OPN	4 STBsw-R
3/8	1/4	62.8	30.5	9.2	19.3	16.8	5.8	16	19	17	55.5	23.2	32.3	22.9	4 OPN	6-4 STBsw-R
1/2	3/8	73.0	36.0	9.4	21.8	22.9	7.8	22	22	22	62.9	25.9	37.0	26.4	6 OPN	8-6 STBsw-R
1/2	1/2	81.5	38.1	13.0	21.8	24.4	10.4	24	27	22	71.3	27.9	43.4	32.0	8 OPN	8 STBsw-R
5/8	1/2	81.5	38.1	13.0	21.8	24.4	10.4	24	27	25	71.3	27.9	43.4	32.0	8 OPN	10-8 STBsw-R
3/4	1/2	85.1	39.9	13.0	21.8	24.4	10.4	27	27	28.5	74.9	29.7	45.2	32.0	8 OPN	12-8 STBsw-R
3/4	3/4	88.7	39.9	13.0	21.8	24.4	15.8	27	35	28.5	78.5	29.7	48.8	41.2	12 OPN	12 STBsw-R
1	1	102.6	49.0	14.0	26.4	31.2	19.8	35	41	38	90.4	36.8	53.6	48.5	16 OPN	16 STBsw-R

Metric OD Tubes X Male ISO* Parallel Threads



T Tube OD	P ISO MALE	A	AX	B	C	D	E min.	F A/F	FX A/F	G A/F	H A/F	HX	HY	U	O Ring Part No.	Fluid Controls Part No.
6	1/8	53.4	27.0	8.1	17.7	15.3	4.0	14	14	14	46.0	19.6	26.4	17.3	2 OPN	STBsw 6-2R
6	1/4	61.3	29.0	9.1	17.7	15.3	4.8	16	19	14	53.9	21.6	32.3	22.9	4 OPN	STBsw 6-4R
8	1/8	56.2	28.8	8.1	18.6	16.2	4.0	14	14	16	48.7	21.3	27.4	17.3	2 OPN	STBsw 8-2R
8	1/4	62.1	29.9	9.1	18.6	16.2	5.9	16	19	16	54.6	22.4	32.2	22.9	4 OPN	STBsw 8-4R
10	1/4	68.5	33.5	9.1	19.5	17.2	5.9	19	19	19	61.9	25.9	35.0	22.9	4 OPN	STBsw 10-4R
12	3/8	73.1	36.0	9.4	22.0	22.8	7.9	22	22	22	63.0	25.9	37.1	26.4	6 OPN	STBsw 12-6R
12	1/2	81.4	38.0	13.0	22.0	23	9.5	24	27	22	71.3	27.9	43.4	32.0	8 OPN	STBsw 12-8R
16	1/2	83.3	38.1	13.0	22.0	24.4	11.9	27	27	28.5	74.9	29.7	45.2	32.0	8 OPN	STBsw 16-8R
22	3/4	93.4	44.6	13.0	22.0	26.0	15.8	27	35	28.5	83.3	34.5	48.8	41.2	12 OPN	STBsw 22-12R
25	3/4	102.3	49.0	13.0	26.5	31.3	15.8	35	35	38	90.1	36.8	53.3	41.2	12 OPN	STBsw 25-12R
25	1	102.6	49.0	14.0	26.5	31.3	21.8	35	41	38	90.4	36.8	53.6	48.5	16 OPN	STBsw 25-16R

* Reference Specifications : BS 2779 : ISO 228/1 : JIS B0202 : DIN-ISO 228/1

POSITIONABLE MALE RUN TEE

INCH OD Tubes x SAE/MS *Straight threads

T Tube OD	S SAE/MS Male	A	Ax	B	C	D	E min.	F A/F	Fx A/F	G A/F	H	Hx	Hy	U	O Ring Part No.	Fluid Controls Part No.
1/4	7/16-20	57.0	28.5	9.9	17.8	15.3	4.8	14	14	14	49.5	21.0	28.5	16.5	4 OPU	4 STRsw-U
3/8	9/16-18	64.3	32.0	11.2	19.3	16.8	7.1	16	17	17	56.9	24.6	32.3	20.0	6 OPU	6 STRsw-U
1/2	3/4-16	75.4	37.6	12.7	21.8	22.9	10.4	22	22	22	65.2	27.4	37.8	25.6	8 OPU	8 STRsw-U
3/4	11/16-12	90.2	41.4	16.8	21.8	24.4	15.8	27	32	28.5	80.0	31.2	48.8	36.6	12 OPU	12 STRsw-U
1	15/16-12	104.1	50.5	16.8	26.4	31.2	22.3	35	35	38	92.0	38.4	53.6	44.0	16 OPU	16 STRsw-U
1.1/4	15/8-12	126.0	67.8	16.8	38.9	41.2	27.6	46	50	50	103.9	45.7	58.2	54.9	20 OPU	20 STRsw-U
1.1/2	17/8-12	138.4	78.0	16.8	45.2	50.0	34.0	50	55	60	111.2	50.8	60.4	62.5	24 OPU	24 STRsw-U

METRIC OD Tubes x SAE/MS *Straight threads

T Tube OD	S SAE/MS Male	A	Ax	B	C	D	E min.	F A/F	Fx A/F	G A/F	H	Hx	Hy	U	O Ring Part No.	Fluid Controls Part No.
6	7/16-20	57.0	28.5	9.9	17.7	15.3	4.8	14	14	14	49.5	21.0	28.5	16.5	4 OPU	STRsw-6-U
10	9/16-18	64.3	32.0	11.2	19.5	17.2	7.1	16	17	17	56.9	24.6	32.3	20.0	6 OPU	STRsw-10-U
12	3/4-16	75.4	37.6	12.7	22.0	22.8	10.4	22	22	22	65.2	27.4	37.8	25.6	8 OPU	STRsw-12-U
20	11/16-12	90.2	41.4	16.8	22.0	26.0	15.8	27	32	28.5	80.0	31.2	48.8	36.6	12 OPU	STRsw-20-U
25	15/16-12	104.1	50.5	16.8	26.5	31.3	22.3	35	35	38	92.0	38.4	53.6	44.0	16 OPU	STRsw-25-U
2	15/8-12	126.0	67.8	16.8	41.6	42.0	27.6	46	50	50	103.9	45.7	58.2	54.9	20 OPU	STRsw-32-U
38	17/8-12	138.4	78.0	16.8	47.6	49.4	34.0	50	55	60	111.2	50.8	60.4	62.5	24 OPU	STRsw-38-U

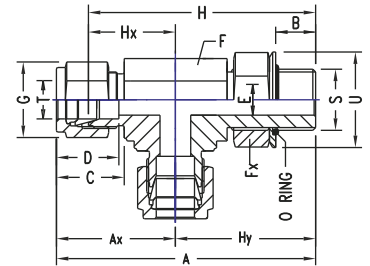

POSITIONABLE MALE BRANCH TEE

INCH OD Tubes x SAE/MS *Straight threads

T Tube OD	S SAE/MS Male	A	Ax	B	C	D	E min.	F A/F	Fx A/F	G A/F	H	Hx	Hy	U	O Ring Part No.	Fluid Controls Part No.
1/4	7/16-20	57.0	28.5	9.9	17.8	15.3	4.8	14	14	14	42.0	21.0	28.5	16.5	4 OPU	4 STBsw-U
3/8	9/16-18	64.0	32.0	11.2	19.3	16.8	7.1	16	17	17	49.2	24.6	32.3	20.0	6 OPU	6 STBsw-U
1/2	3/4-16	75.2	37.6	12.7	21.8	22.9	10.4	22	22	22	54.8	27.4	37.8	25.6	8 OPU	8 STBsw-U
3/4	11/16-12	82.8	41.4	16.8	21.8	24	15.8	27	32	28.5	62.4	31.2	48.8	36.6	12 OPU	12 STBsw-U
1	15/16-12	101.0	50.5	16.8	26.4	31.2	22.3	35	35	38	76.8	38.4	53.6	44.0	16 OPU	16 STBsw-U
1.1/4	15/8-12	135.6	68	16.8	38.9	41.2	27.6	46	50	50	91.4	46	58	55	20 OPU	20 STBsw-U
1.1/2	17/8-12	156.0	78.0	16.8	45.2	50.0	34.0	50	55	60	101.6	51	60	63	24 OPU	24 STBsw-U

METRIC OD Tubes x SAE/MS *Straight threads

T Tube OD	S SAE/MS Male	A	Ax	B	C	D	E min.	F A/F	Fx A/F	G A/F	H	Hx	Hy	U	O Ring Part No.	Fluid Controls Part No.
6	7/16-20	57.0	28.5	9.9	17.7	15.3	4.8	14	14	14	42.0	21.0	28.5	16.5	4 OPU	STBsw-6-U
10	9/16-18	64.0	32.0	11.2	19.5	17.2	7.1	16	17	17	49.2	24.6	32.3	20.0	6 OPU	STBsw-10-U
12	3/4-16	75.2	37.6	12.7	22.0	22.8	10.4	22	22	22	54.8	27.4	37.8	25.6	8 OPU	STBsw-12-U
20	11/16-12	82.8	41.4	16.8	22.0	26.0	15.8	27	32	28.5	62.4	31.2	48.8	36.6	12 OPU	STBsw-20-U
25	15/16-12	101.0	50.5	16.8	26.5	31.3	22.3	35	35	38	76.8	38.4	53.6	44.0	16 OPU	STBsw-25-U
32	15/8-12	135.6	68	16.8	41.6	42.0	27.6	46	50	50	91.4	46	58	55	20 OPU	STBsw-32-U
38	17/8-12	156.0	78.0	16.8	47.6	49.4	34.0	50	55	60	101.6	51	60	63	24 OPU	STBsw-38-U

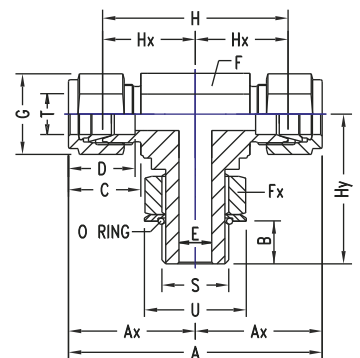

* Reference Specifications : SAE Screw Thread standard conforms to American standard B1.1. Unified screw threads.

FEMALE CONNECTOR

INCH OD Tubes x Female NPT Threads

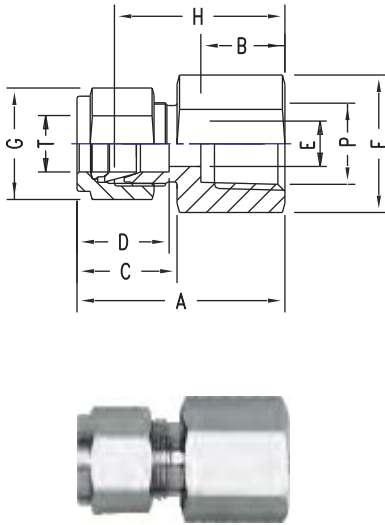

T Tube OD	P NPT Female	A	B	C	D	E min.	F A/F	G A/F	H	Fluid Controls Part No.
1/16	1/16	23.6	9.9	11.0	8.6	1.3	11	8	19.8	1 SCF-N
1/16	1/8	24.4	10.4	11.0	8.6	1.3	14	8	20.6	1-2 SCF-N
1/8	1/8	28.7	10.4	15.3	12.7	2.4	14	11	22.1	2 SCF-N
1/8	1/4	33.6	15.0	15.3	12.7	2.4	19	11	26.9	2-4 SCF-N
1/4	1/8	31.2	9.9	17.8	15.3	4.8	14	14	23.9	4-2 SCF-N
1/4	1/4	35.8	15.0	17.8	15.3	4.8	19	14	28.5	4 SCF-N
1/4	3/8	37.6	15.0	17.8	15.3	4.8	22	14	30.2	4-6 SCF-N
1/4	1/2	42.4	19.8	17.8	15.3	4.8	27	14	35.0	4-8 SCF-N
5/16	1/8	32.0	10.4	18.5	16.3	6.3	14	16	24.6	5-2 SCF-N
5/16	1/4	36.8	15.0	18.5	16.3	6.3	19	16	29.5	5-4 SCF-N
3/8	1/8	32.8	10.4	19.3	16.8	7.1	16	17	25.4	6-2 SCF-N
3/8	1/4	37.6	15.0	19.3	16.8	7.1	19	17	30.2	6-4 SCF-N
3/8	3/8	39.1	15.0	19.3	16.8	7.1	22	17	31.8	6 SCF-N
3/8	1/2	43.9	19.8	19.3	16.8	7.1	27	17	36.6	6-8 SCF-N
1/2	1/4	40.4	15.0	21.8	22.9	10.4	22	22	30.2	8-4 SCF-N
1/2	3/8	41.9	15.0	21.8	22.9	10.4	22	22	30.2	8-6 SCF-N
1/2	1/2	46.7	19.8	21.8	22.9	10.4	27	22	36.6	8 SCF-N
1/2	3/4	48.3	20.6	21.8	22.9	10.4	32	22	38.1	8-12 SCF-N
5/8	3/8	41.9	15.0	21.8	24.4	12.7	24	25	31.8	10-6 SCF-N
5/8	1/2	46.7	19.8	21.8	24.4	12.7	27	25	36.6	10-8 SCF-N
3/4	1/2	46.7	19.8	21.8	24.4	15.8	27	28.5	36.6	12-8 SCF-N
3/4	3/4	48.3	20.6	21.8	24.4	15.8	35	28.5	38.1	12 SCF-N
7/8	3/4	49.8	20.6	21.8	25.9	18.3	35	32	39.6	14-12 SCF-N
1	3/4	53.4	20.6	26.4	31.2	22.3	35	38	41.2	16-12 SCF-N
1	1	62.3	25.4	26.4	31.2	22.3	41	38	50.0	16 SCF-N
1.1/4	1.1/4	74.6	25.4	38.9	41.2	27.6	55	50	52.6	20 SCF-N
1.1/2	1.1/2	83.3	27.6	45.2	50.0	34.0	60	60	56.2	24 SCF-N

INCH OD Tubes x Female ISO* Tapered Pipe Threads

T Tube OD	P ISO Female	A	B	C	D	E min.	F A/F	G A/F	H	Fluid Controls Part No.
1/16	1/16	23.6	9.9	11.0	8.6	1.3	11	8	19.8	1 SCF-Rx
1/8	1/8	28.7	10.4	15.3	12.7	2.4	14	11	22.1	2 SCF-Rx
1/8	1/4	33.6	15.0	15.3	12.7	2.4	19	11	26.9	2-4 SCF-Rx
1/4	1/8	31.2	9.9	17.8	15.3	4.8	14	14	23.9	4-2 SCF-Rx
1/4	1/4	35.8	15.0	17.8	15.3	4.8	19	14	28.5	4 SCF-Rx
1/4	3/8	37.6	15.0	17.8	15.3	4.8	22	14	30.2	4-6 SCF-Rx
1/4	1/2	42.4	19.8	17.8	15.3	4.8	27	14	35.0	4-8 SCF-Rx
3/8	1/4	37.6	15.0	19.3	16.8	7.1	19	17	30.2	6-4 SCF-Rx
3/8	3/8	39.1	15.0	19.3	16.8	7.1	22	17	31.8	6 SCF-Rx
3/8	1/2	43.9	19.8	19.3	16.8	7.1	27	17	36.6	6-8 SCF-Rx
1/2	1/4	40.4	15.0	21.8	22.9	10.4	22	22	40.4	8-4 SCF-Rx
1/2	3/8	41.9	15.0	21.8	22.9	10.4	22	22	30.2	8-6 SCF-Rx
1/2	1/2	46.7	19.8	21.8	22.9	10.4	27	22	31.8	8 SCF-Rx
3/4	1/2	46.7	19.8	21.8	24.4	15.8	27	28.5	36.6	12-8 SCF-Rx
3/4	3/4	48.3	20.6	21.8	24.4	15.8	35	28.5	38.1	12 SCF-Rx
1	3/4	53.4	20.6	26.4	31.2	22.3	35	38	41.2	16-12 SCF-Rx
1	1	62.3	25.4	26.4	31.2	22.3	41	38	50.0	16 SCF-Rx
1.1/4	1.1/4	74.6	25.4	38.9	41.2	27.6	55	50	52.6	20 SCF-Rx
1.1/2	1.1/2	83.3	27.6	45.2	50.0	34.0	60	60	56.2	24 SCF-Rx

* Reference Specifications : BS 21: ISO 7/1 : JIS B 0203 : DIN 2999 : IS 554

* Female connectors with Parallel ISO Female Threads to BS:2779; ISO 228/1; JIS B6202; DIN 259 are also Available. Their Dimensions are as same as ISO. Tapered Pipe Threads above. Please consult us.

NOTE: The combinations shown above are representative of various possibilities. Other combinations not shown are also available. Please consult us.

FEMALE CONNECTOR

METRIC OD Tubes x Female NPT Threads



T Tube OD	P NPT Female	A	B	C	D	E min.	F A/F	G A/F	H	Fluid Controls Part No.
3	1/8	28.7	10.4	15.3	12.9	2.4	14	11	22.1	SCF 3-2N
3	1/4	33.5	15.0	15.3	12.9	2.4	19	11	26.9	SCF 3-4N
6	1/8	31.3	10.4	17.7	15.3	4.8	14	14	23.9	SCF 6-2N
6	1/4	35.8	15.0	17.7	15.3	4.8	19	14	28.4	SCF 6-4N
6	3/8	37.6	15.0	17.7	15.3	4.8	22	14	30.2	SCF 6-N
6	1/2	42.5	19.8	17.7	15.3	4.8	27	14	35.1	SCF 6-8N
8	1/8	32.1	10.4	18.6	16.2	6.3	14	16	24.6	SCF 8-2N
8	1/4	37.0	15.0	18.6	16.2	6.3	19	16	29.5	SCF 8-4N
8	3/8	38.5	15.0	18.6	16.2	6.3	22	16	31.0	SCF 8-6N
8	1/2	43.3	19.8	18.6	16.2	6.3	27	16	35.8	SCF 8-N
10	1/4	37.8	15.0	19.5	17.2	7.9	19	19	30.2	SCF 10-4N
10	3/8	39.4	15.0	19.5	17.2	7.9	22	19	31.8	SCF 10-6N
10	1/2	44.2	19.8	19.5	17.2	7.9	27	19	36.6	SCF 10-8N
12	1/4	40.3	15.0	22.0	22.8	9.5	22	22	30.2	SCF 12-4N
12	3/8	41.9	15.0	22.0	22.8	9.5	22	22	31.8	SCF 12-6N
12	1/2	46.7	19.8	22.0	22.8	9.5	27	22	36.6	SCF 12-8N
15	1/2	46.7	19.8	22.0	24.4	11.9	27	25	36.6	SCF 15 8N
16	1/2	46.9	19.8	22.0	24.4	12.7	27	25	36.8	SCF 16-8N
20	1/2	47.9	19.8	22.0	26.0	15.9	30	32	37.8	SCF 20-8N
20	3/4	49.7	20.6	22.0	26.0	15.9	35	32	39.6	SCF 20-12N
22	3/4	49.7	20.6	22.0	26.0	18.3	35	32	39.6	SCF 22-12N
22	1	57.9	25.4	22.0	26.0	18.3	41	32	47.8	SCF 22 16N
25	3/4	53.4	20.6	26.5	31.3	21.8	35	38	41.1	SCF 25-12N
25	1	62.3	25.4	26.5	31.3	21.8	41	38	50.0	SCF 25-16N
32	1.1/4	74.6	25.4	41.6	42.0	27.6	55	50	52.6	SCF32-20N
38	1.1/2	83.3	27.6	47.9	49.4	34.0	60	60	56.2	SCF 38-24N

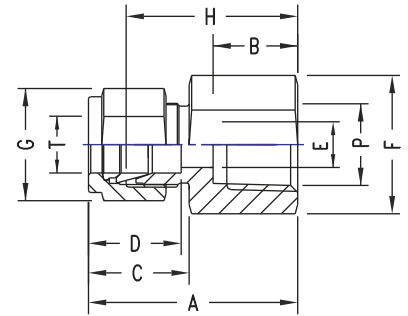

METRIC OD Tubes x Female ISO* Tapered Pipe Threads

T Tube OD	P ISO Female	A	B	C	D	E min.	F A/F	G A/F	H	Fluid Controls Part No.
3	1/8	28.7	10.4	15.3	12.9	2.4	14	11	22.1	SCF 3-2Rx
3	1/4	33.5	15.0	15.3	12.9	2.4	19	11	26.9	SCF 3-4Rx
6	1/8	31.3	10.4	17.7	15.3	4.8	14	14	23.9	SCF 6-2Rx
6	1/4	35.8	15.0	17.7	15.3	4.8	19	14	28.4	SCF 6-4Rx
6	3/8	37.6	15.0	17.7	15.3	4.8	22	14	30.2	SCF 6-Rx
6	1/2	42.5	19.8	17.7	15.3	4.8	27	14	35.1	SCF 6-8Rx
8	1/8	32.1	10.4	18.6	16.2	6.3	14	16	24.6	SCF 8-2Rx
8	1/4	37.0	15.0	18.6	16.2	6.3	19	16	29.5	SCF 8-4Rx
8	3/8	38.5	15.0	18.6	16.2	6.3	22	16	31.0	SCF 8-6Rx
8	1/2	43.3	19.8	18.6	16.2	6.3	27	16	35.8	SCF 8-Rx
10	1/4	37.8	15.0	19.5	17.2	7.9	19	19	30.2	SCF 10-4Rx
10	3/8	39.4	15.0	19.5	17.2	7.9	22	19	31.8	SCF 10-6Rx
10	1/2	44.2	19.8	19.5	17.2	7.9	27	19	36.6	SCF 10-8Rx
12	1/4	40.3	15.0	22.0	22.8	9.5	22	22	30.2	SCF 12-4Rx
12	3/8	41.9	15.0	22.0	22.8	9.5	22	22	31.8	SCF 12-6Rx
12	1/2	46.7	19.8	22.0	22.8	9.5	27	22	36.6	SCF 12-8Rx
15	1/2	46.7	19.8	22.0	24.4	11.9	27	25	36.6	SCF 15 8Rx
16	1/2	46.9	19.8	22.0	24.4	12.7	27	25	36.8	SCF 16-8Rx
22	3/4	49.7	20.6	22.0	26.0	18.3	35	32	39.6	SCF 22-12Rx
22	1	57.9	25.4	22.0	26.0	18.3	41	32	47.8	SCF 22-16Rx
25	3/4	53.4	20.6	26.5	31.3	21.8	35	38	41.1	SCF 25-12Rx
25	1	62.3	25.4	26.5	31.3	21.8	41	38	50.0	SCF 25-16Rx
32	1.1/4	74.6	25.4	41.6	42.0	27.6	55	50	52.6	SCF32-20Rx
38	1.1/2	83.3	27.6	47.9	49.4	34.0	60	60	56.2	SCF 38-24Rx

* Reference Specifications : BS 21: ISO 7/1 : JIS B 0203 : DIN 2999 : IS 554

NOTE: The combinations shown above are representative of various possibilities. Other combinations not shown are also available. Please consult us.

FEMALE MANOMETER CONNECTOR

Inch OD Tubes X Female Iso* Parallel Threads (gage)

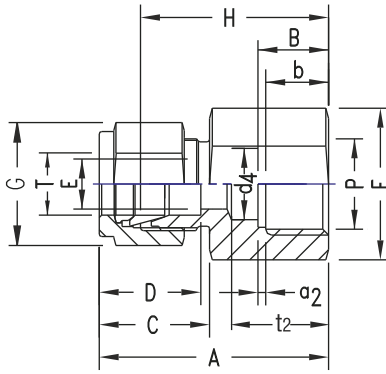

T Tube OD	P ISO Female	A	B	C	D	E min.	F A/F	G A/F	H	a2 Minm.	d4 Minm.	b	t2	Fluid Controls Part No.
1/4	1/4	37.6	13.0	17.8	15.3	4.8	19	14	30.2	1.6	5.6	9.4	17.0	4 SCF-MAN
1/4	3/8	37.6	14.2	17.8	15.3	4.8	24	14	30.2	1.6	6.6	9.9	20.3	4-6 SCF-MAN
1/4	1/2	43.4	18.8	17.8	15.3	4.8	27	14	36.0	1.6	6.6	14.5	24.9	4-8 SCF-MAN
5/16	1/4	38.4	13.0	18.5	16.3	6.0	19	16	31.0	1.6	-	9.4	-	5-4 SCF-MAN
5/16	1/2	40.9	18.8	18.5	16.3	7.1	27	16	33.6	1.6	-	14.5	-	5-8 SCF-MAN
3/8	1/4	39.2	13.0	19.3	16.8	6.0	19	17	31.8	1.6	-	9.4	-	6-4 SCF-MAN
3/8	3/8	38.6	14.2	19.3	16.8	6.6	24	17	31.2	1.6	-	9.9	-	6 SCF-MAN
3/8	1/2	41.9	18.8	19.3	16.8	7.1	27	17	34.5	1.6	-	14.5	-	6-8 SCF-MAN
1/2	3/8	44.5	14.2	21.8	22.9	6.6	24	22	34.3	1.6	-	9.9	-	8-6 SCF-MAN
1/2	1/2	48.3	18.8	21.8	22.9	7.1	27	22	38.1	1.6	-	14.5	-	8 SCF-MAN

Metric OD Tubes X Female ISO* Parallel Thread (gage)



T Tube OD	P ISO Female	A	B	C	D	E min.	F A/F	G A/F	H	a2 min	b min	d4	t2	Fluid Controls Part No.
3	1/4	35.3	12.9	15.3	12.9	2.4	19	11	28.7	1.6	9.5	5.5	17.0	SCF 3-4MAN
6	1/4	37.6	12.9	17.7	15.3	4.8	19	14	30.2	1.6	9.5	5.5	17.0	SCF 6-4MAN
6	3/8	37.6	14.1	17.7	15.3	4.8	24	14	30.2	1.6	10.0	6.5	20.3	SCF 6MAN
6	1/2	43.5	18.9	17.7	15.3	4.8	27	14	36.1	1.6	14.5	7.0	24.9	SCF 6-8MAN
8	1/4	38.5	12.9	18.6	16.2	5.5	19	16	31.0	1.6	9.5	5.5	-	SCF 8-4MAN
8	3/8	36.2	14.1	18.6	16.2	6.5	24	16	28.7	1.6	10.0	6.5	-	SCF 8-6MAN
8	1/2	41.0	18.9	18.6	16.2	7.1	27	16	33.5	1.6	14.5	7.0	-	SCF 8MAN
10	1/4	39.4	19.5	19.5	17.2	5.5	19	19	31.8	1.6	9.5	5.5	-	SCF 10-4MAN
10	3/8	38.8	19.5	19.5	17.2	6.5	24	19	31.2	1.6	10.0	6.5	-	SCF 10-6MAN
10	1/2	42.1	19.5	19.5	17.2	7.1	27	19	34.5	1.6	14.5	7.0	-	SCF 10-8MAN
12	1/4	41.9	12.9	22.0	22.8	5.5	22	22	31.8	1.6	9.5	5.5	-	SCF 12-4MAN
12	3/8	44.4	14.1	22.0	22.8	6.5	24	22	34.3	1.6	10.0	6.5	-	SCF12-6MAN
12	1/2	48.2	18.9	22.0	22.8	7.1	27	22	38.1	1.6	14.5	7.0	-	SCF 12-8MAN

No seal is made around the male thread. instead, a gasket is dropped into the flat bottom in the female thread, and the end of the male threaded end exerts a load on the gasket to seal. Details of gasket given below.

* Reference Specifications : BS 2779 : ISO 228/1 : JIS B0202 : DIN-259

MANOMETER CONNECTOR GASKET FOR FEMALE ISO PARALLEL THREADS

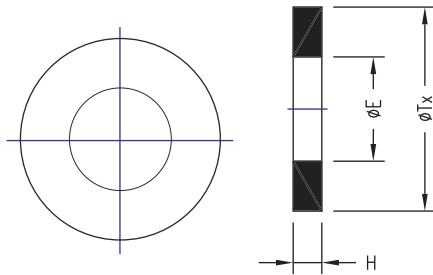

P ISO Female	E	H	Tx	Part No.	
				Copper	PTFE
1/4"	7.6	1.8	10.7	4 MG-Cu	4 MG-PTFE
3/8"	8.6	2.3	14.2	6 MG-Cu	6 MG-PTFE
1/2"	9.1	2.5	17.8	8 MG-Cu	8 MG-PTFE

BULKHEAD FEMALE CONNECTOR

INCH OD Tubes x Female NPT Threads

T Tube OD	P NPT Male	A	Ax	B	D	E min.	F A/F	G A/F	H	Hx	Panel Hole Drill Size	Max. Panel Thick- ness	Fluid Controls Part No.
1/8	1/8	44.7	31.2	10.4	12.7	2.4	14	11	38.1	24.6	8.3	12.7	2 SCFB-N
1/4	1/8	47.0	33.5	10.4	15.3	4.8	16	14	39.7	26.2	11.5	10.2	4-2 SCFB-N
1/4	1/4	51.5	33.5	15.0	15.3	4.8	19	14	44.2	26.2	11.5	10.2	4 SCFB-N
3/8	1/4	54.8	36.8	15.0	16.8	7.1	19	17	47.5	29.5	14.7	11.2	6-4 SCFB-N
1/2	3/8	61.7	41.9	15.0	22.9	10.4	22	22	51.6	31.0	19.5	12.7	8-6 SCFB-N
1/2	1/2	66.7	41.9	19.8	22.9	10.4	27	22	56.6	31.0	19.5	12.7	8 SCFB-N
5/8	1/2	67.6	42.7	19.8	22.9	12.7	27	25	57.4	32.5	22.6	12.7	10-8 SCFB-N
3/4	1/2	72.4	47.5	19.8	24.4	16.0	35	28.5	62.3	37.4	25.8	16.8	12-8 SCFB-N
3/4	3/4	74.7	47.5	20.6	24.4	16.0	35	28.5	64.3	37.4	25.8	16.8	12 SCFB-N
1	3/4	84.3	57.4	20.6	31.2	16.0	35	38	72.1	45.2	33.7	19.0	16-12 SCFB-N
1	1	93.2	57.4	25.4	31.2	22.2	35	38	81.0	45.2	33.7	19.0	16 SCFB-N
1.1/4	1.1/4	105.7	69.9	25.4	41.2	27.6	50	50	83.5	47.7	41.6	19.0	20 SCFB-N
1.1/2	1.1/2	144.5	76.4	27.6	50.0	34.0	60	57	87.4	49.3	49.6	19.0	24 SCFB-N

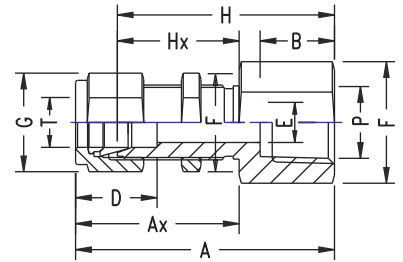

Metric OD Tubes x Female NPT Threads

T Tube OD	P NPT Male	A	Ax	B	D	E min.	F A/F	G A/F	H	Hx	Panel Hole Drill Size	Max. Panel Thick- ness	Fluid Controls Part No.
3	1/8	44.7	31.2	10.4	12.9	2.4	14	11	38.1	24.6	8.3	12.7	SCFB 3-2N
6	1/4	51.6	33.6	15.0	15.3	4.8	19	14	44.2	26.2	11.5	10.2	SCFB 6-4N
10	3/8	56.8	37.0	15.0	17.2	7.9	22	19	49.2	29.4	16.3	11.2	SCFB 10-4N
12	3/8	61.8	41.9	15.0	22.8	9.5	24	22	51.7	31.8	19.5	12.7	SCFB 12-6N
12	1/2	66.7	41.9	19.8	22.8	9.5	27	22	56.6	31.8	19.5	12.7	SCFB 12-8N
16	1/2	67.5	42.6	20.6	24.4	12.7	27	25	57.4	32.5	22.8	12.7	SCFB 16-8N
22	3/4	79.9	53.0	20.6	26.0	15.8	35	35	69.8	42.9	29.0	19.0	SCFB 22-12N
25	3/4	84.3	57.4	20.6	31.2	15.8	35	38	72.1	45.2	33.7	19.0	SCFB 25-12N
25	1	93.2	57.4	25.4	31.2	22.3	35	38	81.0	45.2	33.7	19.0	SCFB 25-16N
32	1.1/4	105.7	69.9	25.4	42.0	27.6	50	50	83.5	44.7	41.6	19.0	SCFB 32-20N
38	1.1/2	114.5	76.4	27.6	49.4	33.7	60	57	87.4	49.3	49.6	19.0	SCFB 38-24N

NOTE: Bulkhead Female Connectors are also available with ISO Taper Female Threads, ISO Parallel Female Threads and ISO Female Marcometer connection. Please consult us.

FEMALE ELBOW

INCH OD Tubes X Female NPT Threads

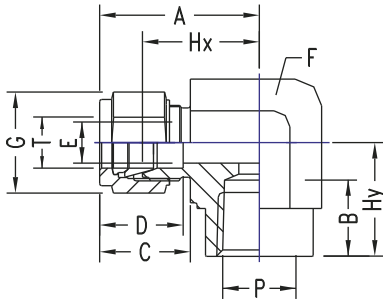

T Tube OD	P NPT Female	A	B	C	D	E min.	F A/F	G A/F	Hx	Hy	Fluid Controls Part No.
1/8	1/8	24.6	10.4	15.3	12.7	2.4	14	11	18.0	19.0	2 SEF-N
1/8	1/4	27.4	15.0	15.3	12.7	2.4	19	11	20.8	22.4	2-4 SEF-N
1/4	1/8	26.9	10.4	17.8	15.3	4.8	14	14	19.6	19.0	4-2 SEF-N
1/4	1/4	29.7	15.0	17.8	15.3	4.8	19	14	22.4	22.4	4 SEF-N
1/4	3/8	31.8	15.0	17.8	15.3	4.8	22	14	24.4	22.4	4-6 SEF-N
1/4	1/2	34.6	19.8	17.8	15.3	4.8	27	14	27.2	28.5	4-8 SEF-N
5/16	1/8	28.7	10.4	17.8	15.3	6.3	19	14	21.4	19.1	5-2 SEF-N
5/16	1/4	30.5	15.0	18.5	16.3	6.3	22	16	23.2	22.4	5-4 SEF-N
3/8	1/8	30.5	10.4	19.3	16.8	7.1	17	17	23.2	19.1	6-2 SEF-N
3/8	1/4	31.2	15.0	19.3	16.8	7.1	19	17	23.9	22.4	6-4 SEF-N
3/8	3/8	33.3	15.0	19.3	16.8	7.1	22	17	25.9	22.4	6 SEF-N
3/8	1/2	36.0	19.8	19.3	16.8	7.1	27	17	28.7	28.5	6-8 SEF-N
1/2	1/4	36.0	15.0	21.8	22.9	7.1	22	22	25.9	22.4	8-4 SEF-N
1/2	3/8	36.0	15.0	21.8	22.9	10.4	22	22	25.9	22.4	8-6 SEF-N
1/2	1/2	38.9	19.8	21.8	22.9	10.4	27	22	28.7	28.5	8 SEF-N
5/8	3/8	38.1	15.0	21.8	22.9	12.7	24	22	28.0	22.4	10-6 SEF-N
5/8	1/2	39.9	19.8	21.8	24.4	12.7	27	25	29.7	28.5	10-8 SEF-N
3/4	1/2	39.9	19.8	21.8	24.4	15.8	27	28.5	29.7	28.5	12-8 SEF-N
3/4	3/4	44.7	20.6	21.8	24.4	15.8	35	28.5	34.6	31.8	12 SEF-N
7/8	3/4	44.7	20.6	21.8	25.9	18.2	35	32	34.6	31.8	14-12 SEF-N
1	3/4	49.0	20.6	26.4	31.2	22.3	35	38	36.8	31.8	16-12 SEF-N
1	1	53.6	25.4	26.4	31.2	22.3	41	38	41.4	38.1	16 SEF-N

METRIC OD Tubes x Female NPT Threads

T Tube OD	P NPT Female	A	B	C	D	E min.	F A/F	G A/F	Hx	Hy	Fluid Controls Part No.
3	1/8	24.6	10.4	15.3	12.9	2.4	14	11	18.0	19.0	SEF 3-2N
3	1/4	27.4	15.0	15.3	12.9	2.4	19	11	20.8	22.4	SEF 3-4N
6	1/8	27.0	10.4	17.7	15.3	4.8	14	14	19.6	19.0	SEF 6-2N
6	1/4	29.8	15.0	17.7	15.3	4.8	19	14	22.4	22.4	SCF 6-4N
6	1/2	34.6	19.8	17.7	15.3	4.8	27	14	27.2	28.5	SEF 6-8N
8	1/4	30.6	15.0	18.6	16.2	6.3	19	16	23.1	22.4	SEF 8-4N
8	3/8	32.6	15.0	18.6	16.2	6.3	22	16	25.1	22.4	SEF 8-6N
10	1/4	33.5	15.0	19.5	17.2	7.9	19	19	25.9	22.4	SEF 10-4N
10	3/8	33.5	15.0	19.5	17.2	7.9	22	19	25.9	22.4	SEF 10-6N
12	1/4	36.0	15.0	22.0	22.8	9.5	22	22	25.9	22.4	SEF 12-4N
12	3/8	36.0	15.0	22.0	22.8	9.5	22	22	25.9	22.4	SEF 12-6N
12	1/2	38.8	19.8	22.0	22.8	9.5	27	22	28.7	28.5	SEF 12-8N
16	1/2	39.5	19.8	22.0	24.4	12.7	27	25	29.7	28.5	SEF 16-8N
25	3/4	49.0	20.6	26.5	31.3	22.3	35	38	36.8	31.8	SEF 25-12N
25	1	53.6	25.4	26.5	31.3	22.3	41	38	41.4	38.1	SEF 25-16N

FEMALE ELBOW

INCH OD Tubes X Female ISO* tapered pipe threads



T Tube OD	P NPT Female	A	B	C	D	E min.	F A/F	G A/F	Hx	Hy	Fluid Controls Part No.
1/8	1/8	24.6	10.4	15.3	12.7	2.4	14	11	18.0	19.0	2 SEF-Rx
1/8	1/4	27.4	15.0	15.3	12.7	2.4	19	11	20.8	22.4	2-4 SEF-Rx
1/4	1/8	26.9	10.4	17.8	15.3	4.8	14	14	19.6	19.0	4-2 SEF-Rx
1/4	1/4	29.7	15.0	17.8	15.3	4.8	19	14	22.4	22.4	4 SEF-Rx
1/4	3/8	31.8	15.0	17.8	15.3	4.8	22	14	24.4	22.4	4-6 SEF-Rx
1/4	1/2	34.6	19.8	17.8	15.3	4.8	27	14	27.2	28.5	4-8 SEF-Rx
5/16	1/8	28.7	10.4	17.8	15.3	6.3	19	14	21.4	19.1	5-2 SEF-Rx
5/16	1/4	30.5	15.0	18.5	16.3	6.3	22	16	23.2	22.4	5-4 SEF-Rx
3/8	1/8	30.5	10.4	19.3	16.8	7.1	17	17	23.2	19.1	6-2 SEF-Rx
3/8	1/4	31.2	15.0	19.3	16.8	7.1	19	17	23.9	22.4	6-4 SEF-Rx
3/8	3/8	33.3	15.0	19.3	16.8	7.1	22	17	25.9	22.4	6 SEF-Rx
3/8	1/2	36.0	19.8	19.3	16.8	7.1	27	17	28.7	28.5	6-8 SEF-Rx
1/2	1/4	36.0	15.0	21.8	22.9	7.1	22	22	25.9	22.4	8-4 SEF-Rx
1/2	3/8	36.0	15.0	21.8	22.9	10.4	22	22	25.9	22.4	8-6 SEF-Rx
1/2	1/2	38.9	19.8	21.8	22.9	10.4	27	22	28.7	28.5	8 SEF-Rx
5/8	3/8	38.1	15.0	21.8	22.9	12.7	24	22	28.0	22.4	10-6 SEF-Rx
5/8	1/2	39.9	19.8	21.8	24.4	12.7	27	25	29.7	28.5	10-8 SEF-Rx
3/4	1/2	39.9	19.8	21.8	24.4	15.8	27	28.5	29.7	28.5	12-8 SEF-Rx
3/4	3/4	44.7	20.6	21.8	24.4	15.8	35	28.5	34.6	31.8	12 SEF-Rx
7/8	3/4	44.7	20.6	21.8	25.9	18.2	35	32	34.6	31.8	14-12 SEF-Rx
1	3/4	49.0	20.6	26.4	31.2	22.3	35	38	36.8	31.8	16-12 SEF-Rx
1	1	53.6	25.4	26.4	31.2	22.3	41	38	41.4	38.1	16 SEF-Rx

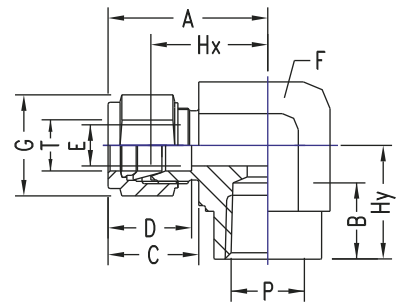

METRIC OD Tubes x Female ISO* tapered pipe threads

T Tube OD	P NPT Female	A	B	C	D	E min.	F A/F	G A/F	Hx	Hy	Fluid Controls Part No.
3	1/8	24.6	10.4	15.3	12.9	2.4	14	11	18.0	19.0	SEF 3-2Rx
3	1/4	27.4	15.0	15.3	12.9	2.4	19	11	20.8	22.4	SEF 3-4Rx
6	1/8	27.0	10.4	17.7	15.3	4.8	14	14	19.6	19.0	SEF 6-2Rx
6	1/4	29.8	15.0	17.7	15.3	4.8	19	14	22.4	22.4	SCF 6-4Rx
6	1/2	34.6	19.8	17.7	15.3	4.8	27	14	27.2	28.5	SEF 6-8Rx
8	1/4	30.6	15.0	18.6	16.2	6.3	19	16	23.1	22.4	SEF 8-4Rx
8	3/8	32.6	15.0	18.6	16.2	6.3	22	16	25.1	22.4	SEF 8-6Rx
10	1/4	33.5	15.0	19.5	17.2	7.9	19	19	25.9	22.4	SEF 10-4Rx
10	3/8	33.5	15.0	19.5	17.2	7.9	22	19	25.9	22.4	SEF 10-6Rx
12	1/4	36.0	15.0	22.0	22.8	9.5	22	22	25.9	22.4	SEF 12-4Rx
12	3/8	36.0	15.0	22.0	22.8	9.5	22	22	25.9	22.4	SEF 12-6Rx
12	1/2	38.8	19.8	22.0	22.8	9.5	27	22	28.7	28.5	SEF 12-8Rx
16	1/2	39.5	19.8	22.0	24.4	12.7	27	25	29.7	28.5	SEF 16-8Rx
25	3/4	49.0	20.6	26.5	31.3	22.3	35	38	36.8	31.8	SEF 25-12Rx
25	1	53.6	25.4	26.5	31.3	22.3	41	38	41.4	38.1	SEF 25-16Rx

* Reference Specifications : BS 21: ISO 7/1 : JIS B 0203 : DIN 2999 : IS 554

* Female connectors with Parallel ISO Female Threads to BS:2779; ISO 228/1; JIS B6202; DIN 259 are also available. Their Dimensions are as same as ISO. Tapered Pipe Threads above. Please consult us.

FEMALE RUN TEE

INCH OD Tubes X Female NPT Threads

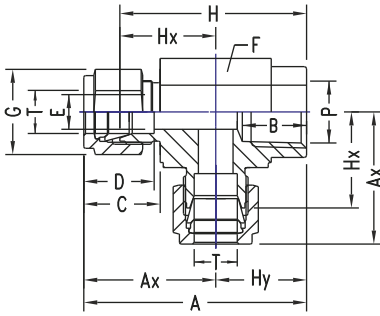

T Tube OD	P NPT Female	A	Ax	B	C	D	E min.	F A/F	G A/F	H	Hx	Hy	Fluid Controls Part No.
1/8	1/8	43.6	24.6	10.4	15.3	12.7	2.4	14	11	37.0	18.0	19.0	2 STRF-N
1/4	1/8	45.9	26.9	10.4	17.8	15.3	4.8	14	14	38.6	19.6	19.0	4-2 STRF-N
1/4	1/4	52.1	29.7	15.0	17.8	15.3	4.8	19	14	44.8	22.4	22.4	4 STRF-N
3/8	1/4	53.6	31.2	15.0	19.3	16.8	7.1	19	17	46.3	23.9	22.4	6-4 STRF-N
3/8	3/8	55.7	33.3	15.0	19.3	16.8	7.1	22	17	48.3	25.9	22.4	6 STRF-N
1/2	3/8	58.4	36.0	15.0	21.8	22.9	10.4	22	22	48.3	25.9	22.4	8-6 STRF-N
1/2	1/2	67.4	38.9	19.8	21.8	22.9	10.4	27	22	57.2	28.7	28.5	8 STRF-N
3/4	3/4	76.5	44.7	20.6	21.8	24.4	15.8	35	29	66.4	34.6	31.8	12 STRF-N
1	3/4	80.8	49.0	20.6	26.4	31	22.3	35	38	68.6	36.8	31.8	16-12 STRF-N
1	1	91.7	53.6	25.4	26.4	31	22.3	41	38	79.5	41.4	38.1	16 STRF-N

METRIC OD Tubes X Female NPT Threads



T Tube OD	P NPT Female	A	Ax	B	C	D	E min.	F A/F	G A/F	H	Hx	Hy	Fluid Controls Part No.
3	1/8	43.6	24.6	10.4	15.3	12.9	2.4	14	11	37.0	18.0	19.0	STRF 3-2N
6	1/8	46.0	27.0	10.4	17.7	15.3	4.8	14	14	38.6	19.6	19.0	STRF 6-2N
6	1/4	52.2	29.8	15.0	17.7	15.3	4.8	19	14	44.8	22.4	22.4	STRF 6-4N
8	1/8	48.9	29.9	10.4	18.6	16.2	6.3	16	16	41.4	22.4	19.0	STRF 8-2N
8	1/4	53.0	30.6	15.0	18.6	16.2	6.3	19	16	45.5	23.1	22.4	STRF 8-4N
10	1/4	55.9	33.5	15.0	19.5	17.2	7.9	19	19	48.3	25.9	22.4	STRF 10-4N
12	3/8	58.4	36.0	15.0	22.0	22.8	9.5	22	22	48.3	25.9	22.4	STRF 12-6N
12	1/2	67.3	38.8	19.8	22.0	22.8	9.5	27	22	57.2	28.7	28.5	STRF 12-8N
16	1/2	68.0	39.5	19.8	22.0	24	12.7	27	25	58.2	29.7	28.5	STRF 16-8N
25	1	91.7	53.6	25.4	26.5	31.3	22.3	41	38	79.5	41.4	38.1	STRF 25-16N

FEMALE BRANCH TEE

INCH OD Tubes X Female NPT Threads

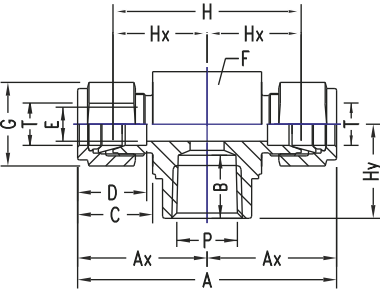

T Tube OD	P NPT Female	A	Ax	B	C	D	E min.	F A/F	G A/F	H	Hx	Hy	Fluid Controls Part No.
1/8	1/8	49.2	24.6	10.4	15.3	12.7	2.4	14	11	36.0	18.0	19.0	2 STBF-N
1/4	1/8	53.8	26.9	10.4	17.8	15.3	4.8	14	14	39.2	19.6	19.0	4-2 STBF-N
1/4	1/4	59.4	27.9	15.0	17.8	15.3	4.8	19	14	44.8	22.4	22.4	4 STBF-N
3/8	1/4	62.4	31.2	15.0	19.3	16.8	7.1	16	16	47.8	23.9	22.4	6-4 STBF-N
3/8	3/8	66.6	33.3	15.0	19.3	16.8	7.1	19	16	51.8	25.9	22.4	6 STBF-N
1/2	3/8	72.0	36.0	15.0	21.8	22.9	10.4	19	19	51.8	25.9	22.4	8-6 STBF-N
1/2	1/2	77.8	38.9	19.8	21.8	22.9	10.4	22	22	57.4	28.7	28.5	8 STBF-N
3/4	3/4	89.4	44.7	20.6	21.8	24.4	15.8	35	22	69.2	34.6	31.8	12 STBF-N
1	3/4	98.0	49.0	20.6	26.4	31.2	22.3	35	25	73.6	36.8	31.8	16-12 STBF-N
1	1	107.2	53.6	25.4	26.4	31.2	22.3	41	38	82.8	41.4	38.1	16 STBF-6N

METRIC Tubes X Female NPT Threads



T Tube OD	P NPT Female	A	Ax	B	C	D	E min.	F A/F	G A/F	H	Hx	Hy	Fluid Controls Part No.
3	1/8	49.2	24.6	10.4	15.3	12.9	2.4	14	11	36.0	18.0	19.0	STBF 3-2N
6	1/8	54.0	27.0	10.4	17.7	15.3	4.8	14	14	39.2	19.6	19.0	STBF 6-2N
6	1/4	59.6	29.8	15.0	17.7	15.3	4.8	19	14	44.8	22.4	22.4	STBF 6-4N
8	1/8	59.8	29.9	10.4	18.6	16.2	6.3	16	16	44.8	22.4	19.0	STBF 8-2N
8	1/4	61.2	30.6	15.0	18.6	16.2	6.3	19	16	46.2	23.1	22.4	STBF 8-4N
10	1/4	67.0	33.5	15.0	19.5	17.2	7.9	19	19	51.8	25.9	22.4	STBF 10-4N
12	3/8	72.0	36.0	15.0	22.0	22.8	9.5	22	22	51.8	25.9	22.4	STBF 12-6N
12	1/2	77.6	38.8	19.8	22.0	22.8	9.5	27	22	57.4	28.7	28.5	STBF 12-8N
16	1/2	79.0	39.5	19.8	22.0	24.4	12.7	27	25	59.4	29.7	28.5	STBF 16-8N
25	1	107.2	53.6	25.4	26.5	31.3	22.3	41	38	82.8	41.4	38.1	STBF 25-16N

NOTE: The combinations shown above are representative of various possibilities. Other combinations not shown are also available. Please consult us.

NOTE: Bulkhead Female Connectors are also available with ISO Taper Female Threads, ISO Parallel Female Threads and ISO Female Marcometer connection. Please consult us.

BUTT WELD PIPE CONNECTOR

INCH OD Tubes to Pipe*

T Tube OD	Pipe Weld Male	A	B	C	D	E min.	F A/F	G A/F	H	J	Fluid Controls Part No.
1/8	1/8	30.5	9.6	15.3	12.7	2.4	11	11	23.9	10.3	2 SC-NB BW
1/4	1/8	32.8	9.6	17.8	15.3	4.8	14	14	25.4	10.3	4-2 CS-NB BW
1/4	1/4	37.8	14.3	17.8	15.3	4.8	14	14	30.5	13.7	4 SC-NB BW
5/16	1/8	34.0	9.6	18.5	16.3	5.1	14	16	26.7	10.3	5-2 SC-NB BW
5/16	1/4	38.6	14.3	18.5	16.3	6.3	16	16	31.2	13.7	5-4 SC-NB BW
3/8	1/4	39.9	14.3	19.3	16.8	7.1	16	17	32.5	13.7	6-4 SC-NB BW
3/8	3/8	39.9	14.3	19.3	16.8	7.1	17	17	32.5	17.2	6 SC-NB BW
3/8	1/2	46.3	19.1	19.3	16.8	7.1	22	17	38.9	21.3	6-8 SC-NB BW
1/2	3/8	43.4	14.3	21.8	22.9	10.4	22	22	33.3	17.2	8-6 SC-NB BW
1/2	1/2	49.0	19.1	21.8	22.9	10.4	22	22	38.9	21.3	8 SC-NB BW
1/2	3/4	50.5	19.1	21.8	22.9	10.4	27	22	40.4	26.7	8-12 SC-NB BW
5/8	1/2	49.0	19.1	21.8	24.4	12.7	24	25	38.9	21.3	10-8 SC-NB BW
3/4	3/4	50.5	19.1	21.8	24.4	15.8	27	29	40.4	26.7	12 SC-NB BW
1	1	62.2	23.8	26.4	31.2	22.3	35	38	50.0	33.4	16 SC-NB BW
1.1/4	1.1/4	77.2	23.8	38.9	41.2	27.6	46	50	55.2	42.2	20 SC-NB BW
1.1/2	1.1/2	88.9	26.2	45.2	50.0	34	55	60	61.7	48.3	24 SC-NB BW

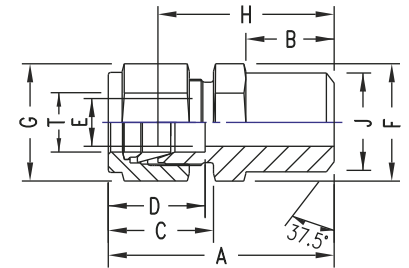

METRIC OD Tubes to Pipe*

T Tube OD	Pipe Weld Male	A	B	C	D	E min.	F A/F	G A/F	H	J	Fluid Controls Part No.
3	1/8	30.5	9.6	15.3	12.9	2.4	11	11	23.9	10.3	SC-NB BW-3-2
6	1/8	32.8	9.6	17.8	15.3	4.8	14	14	25.4	10.3	SC-NB BW-6-2
6	1/4	37.9	14.3	17.8	15.3	4.8	14	14	30.5	13.7	SC-NB BW-6-4
8	1/8	34.2	9.6	18.5	16.3	5.1	16	16	26.7	10.3	SC-NB BW-8-2
8	1/4	38.7	14.3	18.5	16.3	6.3	16	16	31.2	13.7	SC-NB BW-8-4
8	1/2	45.6	19.1	18.5	16.3	6.3	22	16	38.1	21.3	SC-NB BW-8
10	1/4	40.9	14.3	19.5	17.2	7.1	19	19	33.3	13.7	SC-NB BW-10-4
10	3/8	40.9	14.3	19.5	17.2	7.9	19	19	33.3	17.2	SC-NB BW-10-6
10	1/2	46.5	19.1	19.5	17.2	7.9	22	19	38.9	21.3	SC-NB BW-10-8
12	1/4	43.4	14.3	22.0	22.9	7.1	22	22	33.3	13.7	SC-NB BW-12-4
12	3/8	43.4	14.3	22.0	22.9	9.5	22	22	33.3	17.2	SC-NB BW-12-6
12	1/2	49.0	19.1	22.0	22.9	9.5	22	22	38.9	21.3	SC-NB BW-12
16	1/2	49.0	19.1	22.0	24.4	12.7	24	25	38.9	21.3	SC-NB BW-16-8
20	3/4	52.3	19.1	22.0	26	15.9	30	32	42.2	26.7	SC-NB BW-20-12
22	3/4	52.3	19.1	22.0	26	15.9	30	32	42.2	26.7	SC-NB BW-22-12
25	1	62.3	23.8	26.5	31.3	21.8	35	38	50.0	33.4	SC-NB BW-25-16
30	1.1/4	77.2	23.8	39.2	39.6	26.2	45	50	55.6	42.2	SC-NB BW-30-20
32	1.1/4	79.6	23.8	41.6	42.0	28.6	45	50	56.6	42.2	SC-NB BW-32-20
38	1.1/2	91.6	26.2	47.9	49.4	33.7	55	57	64.0	48.3	SC-NB BW-38-24

BUTT WELD PIPE ELBOW

INCH OD Tubes to Pipe*

T Tube OD	Pipe Weld Male	A	B	C	D	E min.	F A/F	G A/F	Hx	Hy	J	Fluid Controls Part No.
1/4	1/8	27.0	9.6	17.8	15.3	4.8	14	14	19.6	18.8	10.3	4-2 SE-NB BW
1/4	1/4	27.0	14.3	17.8	15.3	4.8	14	14	19.6	23.4	13.7	4 SE-NB BW
3/8	1/4	30.5	14.3	19.3	16.8	7.1	16	17	23.1	25.9	13.7	6-4 SE-NB BW
1/2	1/2	36.0	19.1	21.8	22.9	10.4	22	22	25.9	33.0	21.3	8 SE-NB BW
3/4	3/4	39.9	19.1	21.8	24.4	15.8	27	29	29.7	36.8	26.7	12 SE-NB BW
1	1	49.0	23.8	26.4	31.2	22.3	35	38	36.8	46.5	33.4	16 SE-NB BW
1.1/4	1.1/4	66.5	23.8	38.9	41.2	27.6	45	50	44.5	47.8	42.2	20 SE-NB BW
1.1/2	1.1/2	78.0	26.2	45.2	50.0	34.0	50	57	50.8	60.5	48.3	24 SE-NB

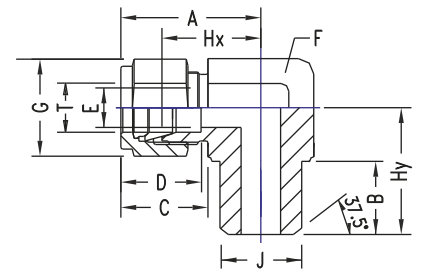

* Reference specification : ANSI B36.19, BS:1387, DIN2391, IS:1239

SOCKET WELD TUBE CONNECTOR

INCH OD Tubes

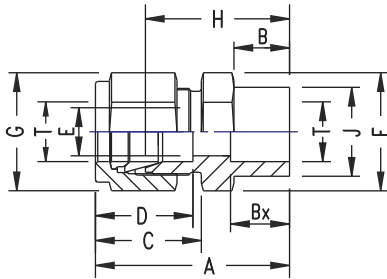

T Tube OD	A	B	Bx	C	D	E min.	F A/F	G A/F	H	J	Fluid Controls Part No.
1/8	29.0	8.6	6.4	15.3	12.7	2.4	11	11	22.9	7.9	2 SC- SW
1/4	33.5	10.4	7.9	17.8	5.3	4.8	14	14	26.2	11.2	4 SC- SW
3/8	37.6	12.0	9.6	19.3	16.8	7.1	16	17	30.3	15.8	6 SC- SW
1/2	41.2	12.0	12.7	21.8	22.9	10.4	22	22	31.0	19.1	8 SC- SW
3/4	43.4	12.0	14.3	21.8	24.4	15.8	27	28.5	33.3	26.7	12 SC- SW
1	52.6	14.3	19.1	26.4	31.2	22.3	35	38	40.4	33.3	16 SC- SW
1.1/4	72.4	19.1	19.1	38.9	41.2	27.6	45	50	50.3	42.0	20 SC- SW
1.1/2	81.8	19.1	23.8	45.2	50.0	34.0	55	57	54.6	50.0	24 SC- SW

METRIC OD Tubes

T Tube OD	A	B	Bx	C	D	E min.	F A/F	G A/F	H	J	Fluid Controls Part No.
3	29.0	8.6	6.4	15.3	12.9	2.4	11	11	22.9	7.9	SC-3- SW
6	33.5	10.4	7.9	17.7	15.3	4.8	14	14	26.2	11.2	SC-6- SW
10	37.6	12.0	9.6	19.5	17.2	7.1	16	17	30.3	15.8	SC-10- SW
12	41.2	12.0	12.7	22.0	22.8	10.4	22	22	31.0	19.1	SC-12- SW
20	43.4	12.0	14.3	22.0	26.0	15.8	27	28.5	33.3	26.7	SC-20- SW
25	52.6	14.3	19.1	26.5	31.3	22.3	35	38	40.4	33.3	SC-25- SW
32	72.4	19.1	19.1	41.6	42.0	27.6	45	50	50.3	42.0	SC-32- SW
38	81.8	19.1	23.8	47.9	49.4	34.0	55	57	54.6	50.0	SC-38- SW

NOTE: Available with socket welded connection for pipes.

SOCKET WELD TUBE ELBOW

INCH OD Tubes

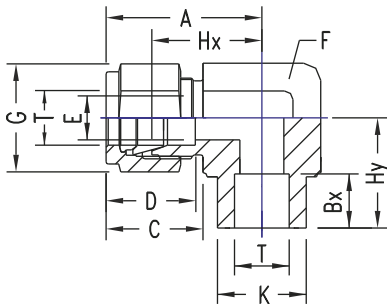

T Tube OD	A	Bx	C	D	E min.	F A/F	G A/F	Hx	Hy	K	Fluid Controls Part No.
1/4	27.0	7.9	17.8	15.3	4.8	14	14	19.6	19.6	12.7	4 SE- SW
3/8	30.5	9.6	19.3	16.8	7.1	16	17	23.1	23.1	15.8	6 SE- SW
1/2	36.0	12.7	21.8	22.9	10.4	22	22	25.9	25.9	20.6	8 SE- SW
3/4	39.9	14.3	21.8	24.4	15.8	27	28.5	29.7	29.7	27.0	12 SE- SW
1	49.0	19.1	26.4	31.2	22.3	35	38	36.8	36.8	35.0	16 SE- SW
1.1/4	66.5	19.1	38.9	41.2	27.6	45	50	44.5	47.8	43.0	20 SE- SW
1.1/2	78.0	23.8	45.2	50.0	34.0	50	57	50.8	60.4	48.0	24 SE- SW

METRIC OD Tubes

T Tube OD	A	B	Bx	C	D	E min.	F A/F	G A/F	H	J	Fluid Controls Part No.
6	27.0	7.9	17.7	15.3	4.8	14	14	19.6	19.6	12.7	SE-6- SW
10	30.5	9.6	19.5	17.2	7.1	16	17	23.1	23.1	15.8	SE-10- SW
12	36.0	12.7	22.0	22.8	10.4	22	22	25.9	25.9	20.6	SE-12- SW
20	39.9	14.3	22.0	26.0	15.8	27	28.5	29.7	29.7	27.0	SE-20- SW
25	49.0	19.1	26.5	31.3	22.3	35	38	36.8	36.8	35.0	SE-25- SW
32	66.5	19.1	41.6	42.0	27.6	45	50	44.5	47.8	43.0	SE-32- SW
38	78.0	23.8	47.9	49.4	34.0	50	57	50.8	60.4	48.0	SE-38- SW

NOTE: Socket weld Tube-to-pipe connections for inch and metric OD tubes to socket weld connections for pipes to ANSI B39.19, BS:1387, DIN:239, IS:1239 also available. Please consult us.

REDUCER

INCH OD Tubes To INCH OD Ports

T Tube OD	Tx Tube OD	A	C	D	E min.	F A/F	G A/F	H	Fluid Controls Part No.
1/8	1/8	33.5	15.3	12.7	2.0	11	11	26.9	2 SR
1/8	1/4	36.0	15.3	12.7	4.8	11	11	29.5	2-4 SR
1/4	1/8	36.8	17.8	15.3	2.0	14	14	29.5	4-2 SR
1/4	1/4	39.1	17.8	15.3	4.8	14	14	31.8	4 SR
1/4	3/8	40.6	17.8	15.3	4.8	14	14	33.3	4-6 SR
1/4	1/2	46.3	17.8	15.3	4.8	14	14	38.9	4-8 SR
5/16	3/8	41.9	18.6	16.3	6.3	14	16	34.6	5-6 SR
5/16	1/2	46.5	18.6	16.3	6.3	14	16	40.2	5-8 SR
3/8	1/4	41.4	19.3	16.8	7.1	16	17	34.0	6-4 SR
3/8	3/8	43.2	19.3	16.8	7.1	16	17	35.8	6 SR
3/8	1/2	48.5	19.3	16.8	7.1	16	17	41.2	6-8 SR
1/2	1/4	45.0	21.8	22.9	4.8	22	22	34.8	8-4 SR
1/2	3/8	46.7	21.8	22.9	7.1	22	22	36.6	8-6 SR
1/2	1/2	52.3	21.8	22.9	9.9	22	22	42.2	8 SR
1/2	3/4	53.8	21.8	22.9	10.4	22	22	43.7	8-12 SR
1/2	1	60.2	21.8	22.9	10.4	22	22	50.0	8-16 SR
5/8	3/4	54.6	21.8	24.4	12.7	24	25	44.5	10-12 SR
5/8	7/8	56.2	21.8	24.4	12.7	24	25	46.0	10-14 SR
3/4	1/2	54.6	21.8	24.4	9.9	27	28.5	44.5	12-8 SR
3/4	1	62.5	21.8	24.4	15.8	27	28.5	52.3	12-16 SR
1	1.1/4	80.5	26.4	31.2	22.3	35	38	68.3	16-20 SR
1	1.1/2	89.2	26.4	31.2	22.3	41	38	77.0	16-24 SR

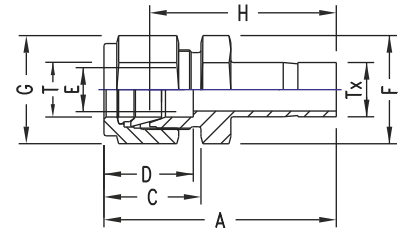

METRIC OD Tubes To METRIC OD Ports

T Tube OD	Tx Tube OD	A	C	D	E min.	F A/F	G A/F	H	Fluid Controls Part No.
3	6	36.1	15.3	12.9	2.4	11	11	29.5	SR 3-6
3	10	38.4	15.3	12.9	2.4	14	11	31.8	SR 3-10
6	3	36.9	17.8	15.3	1.8	14	14	29.5	SR 6-3
6	8	39.9	17.8	15.3	4.8	14	14	32.5	SR 6-8
6	10	40.7	17.8	15.3	4.8	14	14	33.3	SR 6-10
6	12	46.3	17.8	15.3	4.8	14	14	38.9	SR 6-12
8	6	40.3	18.6	16.2	4.6	14	16	32.8	SR 8-6
8	10	42.0	18.6	16.2	6.4	14	16	34.5	SR 8-10
8	12	47.6	18.6	16.2	6.4	14	16	40.1	SR 8-12
10	6	42.4	19.5	17.2	4.6	17	17	34.8	SR 10-6
10	8	43.4	19.5	17.2	6.2	17	17	35.8	SR 10-8
10	12	49.8	19.5	17.2	7.9	17	17	42.2	SR 10-12
12	6	44.9	22.0	22.8	4.6	22	22	34.8	SR 12-6
12	8	45.9	22.0	22.8	6.2	22	22	35.8	SR 12-8
12	10	46.7	22.0	22.8	7.7	22	22	36.6	SR 12-10
12	16	53.8	22.0	22.8	9.5	22	22	43.7	SR 12-16
12	20	56.1	22.0	22.8	9.5	22	22	46.0	SR 12-20
12	22	56.1	22.0	22.8	9.5	24	22	46.0	SR 12-22
12	25	62.4	22.0	22.8	9.5	27	22	53.3	SR 12-25
16	12	53.0	22.0	24.4	9.1	24	25	42.9	SR 16-12
18	12	54.6	22.0	24.4	9.1	27	30	44.5	SR 18-12
18	16	56.1	22.0	24.4	12.7	27	30	46.0	SR 18-16
20	16	57.9	22.0	26.0	12.7	30	32	47.8	SR 20-16
20	25	64.2	22.0	26.0	15.8	30	32	54.1	SR 20-25
22	20	59.4	22.0	26.0	15.1	30	32	49.3	SR 22-20
22	25	64.2	22.0	26.0	18.3	30	32	54.1	SR 22-25
25	18	63.1	26.5	31.3	13.9	35	38	50.8	SR 25-18
25	20	64.6	26.5	31.3	15.1	35	38	52.3	SR 25-20

BULKHEAD REDUCER

INCH OD Tubes

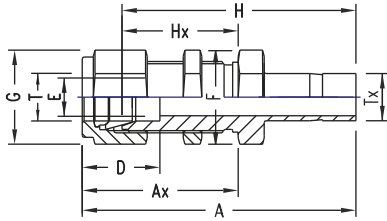

T Tube OD	Tx Tube OD	A	Ax	D	E min.	F A/F	G A/F	H D	Hx	Panel Hole Drill Size	Max. Panel Thick- ness	Fluid Controls Part No.
1/8	1/8	49.5	31.3	12.7	2.0	11	11	43.0	24.6	8.3	12.7	2 SRB
1/4	1/4	55.9	33.5	15.3	4.8	16	14	48.5	26.2	11.5	10.2	4 SRB
3/8	3/8	60.8	36.8	16.8	7.1	19	17	53.8	29.5	14.7	11.2	6 SRB
1/2	1/2	72.9	41.9	22.9	9.9	24	22	62.7	31.8	19.5	12.7	8 SRB
5/8	5/8	75.2	42.7	23.6	12.7	27	25	65.0	32.5	22.6	12.7	10 SRB
1	1	100.4	57.4	31.2	20.3	35	38	88.1	45.2	33.7	19.1	16 SRB
1.1/4	1.1/4	120.7	69.9	41.2	27.4	50	50	89.9	47.7	41.6	19.1	20 SRB
1.1/2	1.1/2	127.2	76.4	50.0	33.0	60	60	100.1	49.3	49.6	19.1	24 SRB

METRIC OD Tubes

T Tube OD	Tx Tube OD	A	Ax	D	E min.	F A/F	G A/F	H	Hx	Panel Hole Drill Size	Max. Panel Thick- ness	Fluid Controls Part No.
6	3	47.1	33.6	15.3	2.0	16	14	39.7	26.2	11.5	10.2	SRB 6-3
6	12	56.6	33.6	15.3	9.1	16	14	49.2	26.2	11.5	10.2	SRB 6-12
8	6	51.8	36.1	16.2	4.6	17	16	44.3	28.6	13.1	11.2	SRB- 8-6
8	12	59.1	36.1	16.2	9.1	17	16	51.6	28.6	13.1	11.2	SRB 8-12
10	8	53.7	37.0	17.2	6.2	22	19	46.1	29.4	16.3	11.2	SRB 10-8
10	12	60.0	37.0	17.2	9.1	22	19	52.4	29.4	16.3	11.2	SRB 10-12
12	6	57.6	41.9	22.8	4.6	24	22	47.5	31.8	19.5	12.7	SRB 12-6
12	10	59.4	41.9	22.8	8.2	24	22	49.3	31.8	19.5	12.7	SRB 12-10
16	12	65.6	42.6	24.4	9.1	27	25	55.5	32.5	22.8	12.7	SRB 16-12
20	16	77.6	53.0	26.0	12.7	35	32	67.5	42.9	29.0	19.1	SRB 20-16
22	18	77.6	53.0	26.0	13.9	35	32	67.5	42.9	29.0	19.1	SRB 22-18
25	20	84.3	57.4	31.2	15.1	35	38	72.1	45.2	33.7	19.1	SRB 25-20
25	22	84.3	57.4	31.2	17.1	35	38	72.1	45.2	33.7	19.1	SRB 25-22
32	32	120.7	69.9	42.0	27.4	50	50	89.9	47.7	41.6	19.1	SRB 32
38	38	127.2	76.4	49.4	33.0	60	60	100.1	49.3	49.6	19.1	SRB 38

NOTE: The REDUCER and BULKHEAD REDUCER shown on page 43 and 44 respectively are only indicative. Other combinations are also available. Please consult us.

MALE ADAPTER

INCH OD Tubes x Male NPT Threads

T Tube OD	P NPT Male	A	B	E min.	F A/F	Fluid Controls Part No.
1/8	1/8	29.5	9.6	4.8	11	2 SAM-N
1/8	1/4	34.8	14.4	7.1	14	2-4 SAM-N
1/4	1/8	31.8	9.6	4.8	11	4-2 SAM-N
1/4	1/4	37.0	14.3	4.8	14	4 SAM-N
1/4	3/8	37.8	14.3	4.8	19	4-6 SAM-N
1/4	1/2	43.4	19.1	4.8	22	4-8 SAM-N
5/16	1/4	38.1	14.3	6.3	14	5-4 SAM-N
3/8	1/4	38.9	14.3	7.1	14	6-4 SAM-N
3/8	3/8	39.6	14.3	7.1	19	6 SAM-N
3/8	1/2	45.2	19.1	7.1	22	6-8 SAM-N
1/2	1/4	44.5	14.3	7.1	14	8-4 SAM-N
1/2	3/8	45.2	14.3	9.9	19	8-6 SAM-N
1/2	1/2	50.8	19.1	9.9	22	8 SAM-N
5/8	1/2	52.3	19.1	11.9	22	10-8 SAM-N
3/4	1/2	52.3	19.1	11.9	22	12-8 SAM-N
3/4	3/4	52.3	19.1	15.0	27	12 SAM-N
1	3/4	58.7	19.1	15.7	27	16 SAM-N
1	1	66.0	23.8	20.3	35	16-12 SAM-N
1.1/4	1.1/4	80.3	23.8	27.6	45	20 SAM-N
1.1/2	1.1/2	94.5	26.2	33.2	55	24 SAM-N

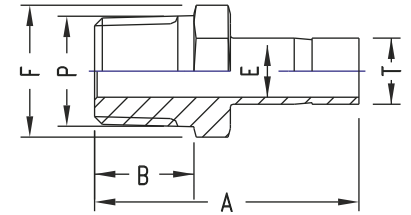

INCH OD Tubes x Male ISO* Tapered Pipe Threads

T Tube OD	P ISO Male	A	B	E min.	F A/F	Fluid Controls Part No.
1/8	1/8	29.5	9.6	4.8	11	2 SAM-Rx
1/8	1/4	34.8	14.4	7.1	14	2-4 SAM-Rx
1/4	1/8	31.8	9.6	4.8	11	4-2 SAM-Rx
1/4	1/4	37.0	14.3	4.8	14	4 SAM-Rx
1/4	3/8	37.8	14.3	4.8	19	4-6 SAM-Rx
1/4	1/2	43.4	19.1	4.8	22	4-8 SAM-Rx
3/8	1/4	38.9	14.3	7.1	14	6-4 SAM-Rx
3/8	3/8	39.6	14.3	7.1	19	6 SAM-Rx
3/8	1/2	45.2	19.1	7.1	22	6-8 SAM-Rx
1/2	1/4	44.5	14.3	7.1	14	8-4 SAM-Rx
1/2	3/8	45.2	14.3	9.9	19	8-6 SAM-Rx
1/2	1/2	50.8	19.1	9.9	22	8 SAM-Rx
3/4	3/4	52.3	19.1	15.0	27	12 SAM-Rx
1	1	66.0	23.8	20.3	35	16-12 SAM-Rx
1.1/4	1.1/4	80.3	23.8	27.6	45	20 SAM-Rx
1.1/2	1.1/2	94.5	26.2	33.2	55	24 SAM-Rx

* Reference Specifications : BS 21: ISO 7/1 : JIS B 0203 : DIN 2999 : IS 554

MALE ADAPTER

METRIC OD Tubes x Male NPT Threads

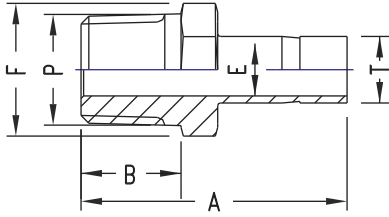

T Tube OD	P NPT Male	A	B	E min.	F A/F	Fluid Controls Part No.
3	1/4	34.8	9.6	7.1	14	SAM 3-2N
6	1/8	32.8	14.3	4.6	14	SAM 6-2N
6	1/4	38.1	14.3	4.6	14	SAM 6-4N
8	1/4	39.1	14.3	6.2	14	SAM 8-4N
10	1/4	39.9	14.3	7.7	14	SAM 10-4N
10	3/8	40.6	14.3	7.7	19	SAM 10-6N
12	1/4	46.5	14.3	7.1	14	SAM 12-4N
12	3/8	46.5	14.3	9.1	19	SAM 12-6N
12	1/2	52.0	14.3	9.1	22	SAM 12-8N
25	3/4	62.0	19.1	15.7	27	SAM 25-12N
25	1	66.8	23.8	15.7	35	SAM 25-16N
30	1	79.2	23.8	22.2	41	SAM 30-16N
30	1.1/4	80.0	23.8	24.6	45	SAM 30-20N
32	1.1/4	81.0	23.8	27.4	46	SAM32-20N
38	1.1/2	92.2	26.2	33.3	55	SAM 38-24N

METRIC OD Tubes x Male ISO* Tapered Pipe Threads

T Tube OD	P ISO Male	A	B	E min.	F A/F	Fluid Controls Part No.
3	1/4	34.8	9.6	7.1	14	SAM 3-2Rx
6	1/8	32.8	14.3	4.6	14	SAM 6-2Rx
6	1/4	38.1	14.3	4.6	14	SAM 6-4Rx
8	1/4	39.1	14.3	6.2	14	SAM 8-4Rx
10	1/4	39.9	14.3	7.7	14	SAM 10-4Rx
10	3/8	40.6	14.3	7.7	19	SAM 10-6Rx
12	1/4	46.5	14.3	7.1	14	SAM 12-4Rx
12	3/8	46.5	14.3	9.1	19	SAM 12-6Rx
12	1/2	52.0	14.3	9.1	22	SAM 12-8Rx
25	3/4	62.0	19.1	15.7	27	SAM 25-12Rx
25	1	66.8	23.8	15.7	35	SAM 25-16Rx
30	1	79.2	23.8	22.2	41	SAM 30-16Rx
30	1.1/4	80.0	23.8	24.6	45	SAM 30-20Rx
32	1.1/4	81.0	23.8	27.4	46	SAM32-20Rx
38	1.1/2	92.2	26.2	33.3	55	SAM 38-24Rx

* Reference Specifications : BS 21: ISO 7/1 : JIS B 0203 : DIN 2999 : IS 554

MALE ADAPTER

INCH OD Tubes x Male ISO* Parallel Threads - RS



T Tube OD	P ISO Male	A	B	E min.	F A/F	Fd	Fluid Controls Part No.
1/8	1/8	31.0	7.1	2.4	14	13.7	2 SAM-Rs
1/8	1/4	35.8	11.2	2.4	19	17.8	2-4 SAM-Rs
1/4	1/8	33.3	7.1	4.0	14	13.7	4-2 SAM-Rs
1/4	1/4	38.1	11.2	4.8	19	17.8	4 SAM-Rs
3/8	1/4	39.9	11.2	5.8	19	17.8	6-4 SAM-Rs
3/8	3/8	40.6	11.2	7.1	22	21.6	6 SAM-Rs
1/2	1/4	45.5	11.2	5.8	19	17.8	8-4 SAM-Rs
1/2	3/8	46.3	11.2	7.9	22	21.6	8-6 SAM-Rs
1/2	1/2	49.3	14.2	9.9	27	26.0	8 SAM-Rs
3/4	3/4	54.9	15.7	15.0	32	31.8	12 SAM-Rs
1	1	64.5	18.2	19.8	41	38.8	16-12 SAM-Rs
1.1/4	1.1/4	79.5	19.8	27.4	50	49.0	20 SAM-Rs
1.1/2	1.1/2	93.7	22.1	33.3	55	54.7	24 SAM-Rs

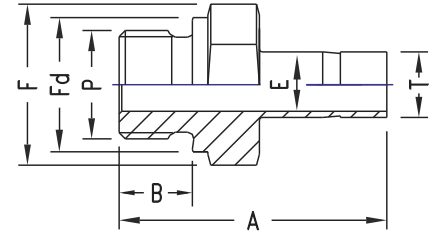

METRIC OD Tubes x Male ISO* Parallel Threads - RS

T Tube OD	P ISO Male	A	B	E min.	F A/F	Fd	Fluid Controls Part No.
3	1/8	31.0	7.1	2.4	14	13.7	SAM 3-2Rs
3	1/4	35.8	11.2	22.0	19	17.8	SAM 3-4Rs
6	1/8	34.3	7.1	4.0	14	13.7	SAM 6-2Rs
6	1/4	39.1	11.2	4.6	19	17.8	SAM 6-4Rs
8	1/4	40.1	11.2	5.8	19	17.8	SAM 8-4Rs
10	1/4	40.9	11.2	5.8	19	17.8	SAM 10-4Rs
10	3/8	41.7	11.2	7.7	22	21.7	SAM 10-6Rs
10	1/2	44.7	14.2	7.7	27	25.9	SAM 10-8Rs
12	1/4	46.7	11.2	5.8	19	17.8	SAM 12-4Rs
12	3/8	47.2	11.2	7.9	22	21.7	SAM 12-6Rs
12	1/2	50.5	14.2	9.1	27	25.9	SAM 12-8Rs
16	1/2	50.5	14.2	12.7	27	25.9	SAM 16-8Rs
22	3/4	55.2	15.7	15.8	35	32.0	SAM 22-12Rs
22	1	64.5	18.3	19.8	41	39.0	SAM 22-16Rs
25	1.1/4	79.5	19.8	27.4	50	49.0	SAM 25-20Rs
25	1.1/2	93.7	22.1	33.3	55	54.7	SAM 25-24Rs

* Reference Specifications : BS 2779 : ISO 228/1 : JIS B0202 : DIN-ISO 228/1

NOTE : 1. For use with soft metal gasket (usually copper) between fitting and female part face
 2. Also available in ISO Parallel Threads - RP series for beaded metal gaskets. See page 22/23 for explanation.

O SEAL MALE ADAPTER

INCH OD Tubes x Male Straight Threads - UNF

T Tube OD	S UNF Male	A	B	E min.	F	Fd A/F	O Ring Part No.	Fluid Controls Part No.
1/8	5/16 - 24	32.5	8.6	2.4	14	13.8	1 OPU	2 SAO-U
1/4	7/16 - 24	39.2	10.4	4.8	19	18.8	2 OPU	4 SAO-U
5/16	1/2 - 24	41.7	11.2	6.3	22	21.8	3 OPU	5 SAO-U
5/16	9/16 - 24	43.2	12.0	7.1	24	23.6	4 OPU	6 SAO-U
1/2	3/4 - 24	49.5	12.0	9.9	27	26.8	6 OPU	8 SAO-U
3/4	11/16 - 12	55.0	14.3	15.0	38	37.8	12 OPU	12 SAO-U
1	15/16 - 12	62.5	14.3	19.8	45	44.0	16 OPU	16 SAO-U
1.1/4	15/8 - 12	79.5	18.3	27.4	55	54.0	20 OPU	20 SAO-U
1.1/2	17/8 - 12	92.2	19.8	33.3	60	58.0	24 OPU	24 SAO-U

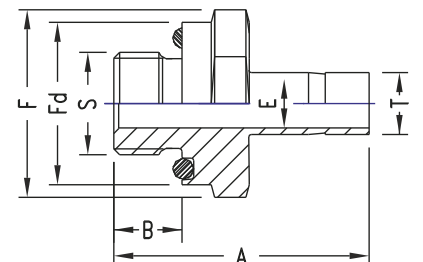

FEMALE ADAPTER

INCH OD Tubes X Female NPT Threads

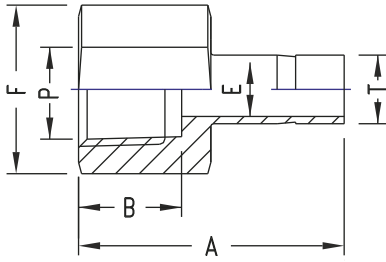

T Tube OD	P NPT Female	A	B	E min.	F A/F	Fluid Controls Part No.
1/8	1/8	31.5	10.4	2.4	14	2 SAF -N
1/8	1/4	35.3	15.0	2.4	19	2-4 SAF -N
1/4	1/8	33.0	10.4	4.8	14	4-2 SAF -N
1/4	1/4	37.0	15.0	4.8	19	4 SAF -N
1/4	3/8	39.4	15.0	4.8	22	4-6 SAF -N
1/4	1/2	45.5	19.8	4.8	27	4-8 SAF -N
5/16	1/4	37.6	15.0	6.3	19	5-4 SAF -N
3/8	1/4	38.1	15.0	7.1	19	6-4 SAF -N
3/8	3/8	40.4	15.0	7.1	22	6 SAF -N
3/8	1/2	46.7	19.8	7.1	27	6-8 SAF -N
1/2	1/4	43.5	15.0	9.9	19	8-4 SAF -N
1/2	3/8	45.5	15.0	9.9	22	8-6 SAF -N
1/2	1/2	51.8	19.8	9.9	27	8 SAF -N
5/8	1/2	53.0	19.8	12.7	27	10-8 SAF -N
3/4	1/2	52.8	19.8	15.0	27	12-8 SAF -N
3/4	3/4	52.8	20.6	15.0	35	12 SAF -N
3/4	1	58.4	25.4	15.0	41	12-16 SAF -N
1	3/4	60.7	20.6	20.3	35	16 SAF -N
1	1	64.3	25.4	20.3	41	16-12 SAF -N
1.1/4	1.1/4	77.7	25.4	27.6	55	20 SAF -N
1.1/2	1.1/2	88.9	27.6	33.2	60	24 SAF -N

INCH OD Tubes X Female ISO* Tapered Pipe Threads

T Tube OD	P ISO Female	A	B	E min.	F A/F	Fluid Controls Part No.
1/4	1/4	37.0	15.0	4.8	19	4 SAF -Rx
1/4	3/8	39.4	15.0	4.8	22	4-6 SAF -Rx
1/4	1/2	45.5	19.8	4.8	27	4-8 SAF -Rx
3/8	1/4	38.1	15.0	7.1	19	6-4 SAF -Rx
3/8	3/8	40.4	15.0	7.1	22	6 SAF -Rx
1/2	1/4	43.5	15.0	9.9	19	8-4 SAF -Rx
1/2	3/8	45.5	15.0	9.9	22	8-6 SAF -Rx
1/2	1/2	51.8	19.8	9.9	27	8 SAF -Rx
3/4	3/4	52.8	20.6	15.0	35	12 SAF -Rx
3/4	1	58.4	25.4	15.0	41	12-16 SAF -Rx
1	3/4	60.7	20.6	20.3	35	16 SAF -Rx
1	1	64.3	25.4	20.3	41	16-12 SAF -Rx
1.1/4	1.1/4	77.7	25.4	27.6	55	20 SAF -Rx
1.1/2	1.1/2	88.9	27.6	33.2	60	24 SAF -Rx

* Reference Specifications : BS 21: ISO 7/1 : JIS B 0203 : DIN 2999 : IS 554

NOTE: Female adaptors are also available with ISO parallel Female Pipe Threads, Their dimensions are same as for similar combination of tube and ISO Taper Pipe Threads. Please consult us.

NOTE: The combinations shown above are representative of various possibilities. Other combinations not shown are also available. Please consult us.

FEMALE ADAPTER

METRIC OD Tubes X Female NPT Threads

T Tube OD	P NPT Female	A	B	E min.	F A/F	Fluid Controls Part No.
3	1/4	31.7	15.0	2.4	14	SAF 3-4N
6	1/8	32.5	9.9	4.6	14	SAF 6-2N
6	1/4	37.1	15.0	4.6	19	SAF 6-4N
8	1/4	37.6	15.0	6.4	19	SAF 8-4N
10	1/4	38.1	15.0	7.7	19	SAF 10-4N
10	3/8	40.1	15.0	7.7	22	SAF 10-6N
10	1/2	46.5	19.8	7.7	27	SAF 10-8N
12	1/4	43.7	15.0	9.1	19	SAF 12-4N
12	1/2	52.3	19.8	9.1	27	SAF 12-8N
16	1/2	47.7	19.8	9.1	27	SAF 16-8N
22	3/4	52.0	20.6	15.0	35	SAF 22-12N
25	3/4	51.2	20.6	15.0	35	SAF 25-12N
25	1	66.5	25.4	19.8	41	SAF 25-16N
32	1.1/4	78.0	25.4	27.4	55	SAF 32-20N
38	1.1/2	88.9	27.6	33.3	60	SAF 38-24N

METRIC OD Tubes X Female ISO* Tapered Pipe Threads

T Tube OD	P ISO Female	A	B	E min.	F A/F	Fluid Controls Part No.
6	1/8	32.5	9.9	4.6	14	SAF 6-2Rx
6	1/4	37.1	15.0	4.6	19	SAF 6-4Rx
8	1/4	37.6	15.0	6.4	19	SAF 8-4Rx
10	1/4	38.1	15.0	7.7	19	SAF 10-4Rx
10	3/8	40.1	15.0	7.7	22	SAF 10-6Rx
12	1/4	43.7	15.0	9.1	19	SAF 12-4Rx
12	1/2	52.3	19.8	9.1	27	SAF 12-8Rx
16	1/2	47.7	19.8	9.1	27	SAF 16-8Rx
22	3/4	52.0	20.6	15.0	35	SAF 22-12Rx
25	3/4	51.2	20.6	15.0	35	SAF 25-12Rx
25	1	66.5	25.4	19.8	41	SAF 25-16Rx
32	1.1/4	78.0	25.4	27.4	55	SAF 32-20Rx
38	1.1/2	88.9	27.6	33.3	60	SAF 38-24Rx

* Reference Specifications : BS 21: ISO 7/1 : JIS B 0203 : DIN 2999 : IS 554

FEMALE MANOMETER ADAPTER

INCH OD Ports X Female ISO* Parallel Threads (gage)

T Tube Od	P ISO Female	A	B	E min.	F A/F	a2	d4	b min.	t2	Fluid Controls Part No.
1/4	1/4	35.3	13.0	4.8	19	1.6	5.8	9.4	17.0	4 SAF-MAN
3/8	3/8	39.4	14.2	6.6	24	1.6	-	9.9	-	6 SAF-MAN
1/2	1/2	45.7	18.8	7.1	27	1.6	-	14.5	-	8 SAF-MAN

METRIC OD Ports X Female ISO* Parallel Threads (gage)

T Tube Od	P ISO Female	A	B	E min.	F A/F	a2	d4	b min.	t2	Fluid Controls Part No.
6	1/4	35.3	12.9	4.6	19	1.6	5.5	9.5	17.0	SAF 6-4MAN
6	3/8	38.4	14.1	4.6	24	1.6	6.5	10.0	20.3	SAF 6MAN
6	1/2	42.9	18.9	4.6	27	1.6	7.0	14.5	24.9	SAF 6-8MAN
8	1/4	33.0	12.9	5.5	19	1.6	-	9.5	-	SAF 8-4MAN
8	1/2	43.7	18.9	6.2	27	1.6	7.0	14.5	24.9	SAF 8MAN
10	1/4	34.5	12.9	5.5	19	1.6	-	9.5	-	SAF 10-4MAN
10	1/2	40.1	18.9	7.0	27	1.6	-	14.5	-	SAF 10-8MAN
12	1/4	40.1	12.9	5.5	19	1.6	-	9.5	-	SAF 12-4MAN
12	1/2	48.8	18.9	7.0	27	1.6	-	14.5	-	SAF 12-8MAN

No seal is made around the male thread. Instead, a gasket is dropped into the flat bottom in the female thread, and the end of the male threaded end exerts a load on the gasket to seal.

* Reference Specifications : BS 2779 : ISO 228/1 : JIS B0202 : DIN-ISO 228/1

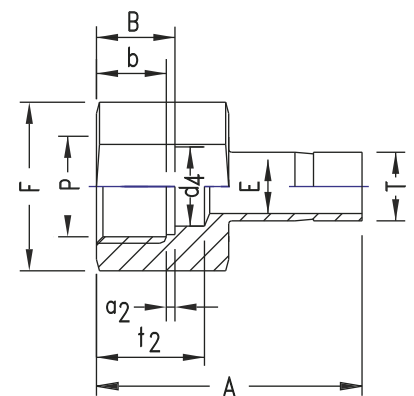
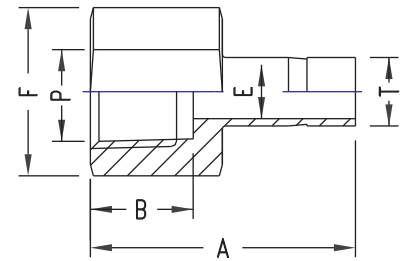



FLUID CONTROLS PRIVATE LIMITED

📍 CORPORATE OFFICE: J.V.Patel I.T.I Compound, B. Madhurkar Marg, Mumbai 400 013, Maharashtra, INDIA

☎ Tel.: +91-22-43338000 | Fax: +91-22-43338001

🌐 Website: www.fluidcontrols.com ✉ Email: sales@fluidcontrols.com

